



SELBORNE 5 SE

SMOKE EXEMPT WOODBURNING STOVE



INSTALLATION & USER INSTRUCTIONS
(TO BE LEFT WITH THE CUSTOMER)

UK & Ireland

GB IE



CONTENTS

| | | | |
|------------------------------------|---------------|-------------------------------|----------------|
| <u>General Safety Notes</u> | <u>Page 2</u> | <u>Operating Instructions</u> | <u>Page 8</u> |
| <u>Chimney & Flue</u> | <u>Page 3</u> | <u>Woodburning</u> | <u>Page 8</u> |
| <u>Flue Draught</u> | <u>Page 5</u> | <u>Maintenance</u> | <u>Page 10</u> |
| <u>Dimensions & Clearances</u> | <u>Page 6</u> | <u>Guarantee</u> | <u>Page 12</u> |
| <u>Installing the Stove</u> | <u>Page 6</u> | | |



GENERAL SAFETY NOTES

- Properly installed, operated and maintained, this appliance will not emit fumes into the dwelling. However occasional fumes from de-ashing and re-fuelling may occur. Persistent fume emissions is potentially dangerous and must not be tolerated. If fume emission does persist, open doors and windows to ventilate the room. Let the fire burn out or eject and safely dispose of fuel from the appliance. Once the fire is cold, check the flue and chimney for blockages and clean if required. Do not attempt to relight the fire until the cause of the fume emission has been identified and corrected. Seek expert advice if necessary.
- Do not fit an extractor fan in the same room as the appliance.
- An adequate air supply for combustion and ventilation is required. As this stove does not exceed 5.0 kW nominal heat output (Refer to Building Regulations Document J) a purpose provided air vent is not normally required. However, in certain circumstances a purpose provided air vent may be necessary – for example, small or tightly sealed rooms. Air openings provided for this purpose must not be restricted.
- It is important that flue ways are cleaned frequently and the chimney swept regularly. Also the stove must be maintained in good mechanical order. Regular sweeping means at least once per year for smokeless fuel and a minimum of twice per year for other fuels.
- If the chimney was previously used for an open fire, it is possible that the higher flue gas temperatures generated by the stove may loosen deposits that were firmly adhering to the inner surface of the chimney and cause blockage of the fluepipe. We recommend that in such a situation a second sweeping of the chimney should be carried out within one month of regular use of the stove after installation. Also, lock or remove any existing dampers in the flueway.
- Should it be likely that children, aged or infirm people approach the fire, then a fireguard should be fitted.
- Avoid the use of aerosol sprays in the vicinity of the stove when it is in operation.
- This appliance must be installed as per these instructions and regulations complied with. No modifications or alterations of any kind are permitted.

INSTALLATION INSTRUCTIONS

The installer has a responsibility under the Health and Safety at Work Act 1974 to provide for the safety of persons carrying out the installation. Attention is drawn to the fact that fire cement is caustic and hands must be washed thoroughly after use. The appliance is heavy and care must be taken during handling. Although the appliance does not contain asbestos products, it is possible that asbestos may be disturbed in existing installations and every precaution must be taken.

These instructions give a guide for the installation of the appliance but in no way absolves the installer from responsibilities to confirm to British Standards, in particular BS9303 and BS6461, relating to the installation of solid fuel appliances. All local regulations, including those referring to National and European standards need to be complied with when installing the appliance.

Warning: Parts of the appliance, especially the external surfaces, will be hot to touch when in operation and due care will need to be taken.

CHIMNEY & FLUE

This successful operation of these appliances relies on the adequate performance of the chimney to which it is connected. The chimney must:

- Have an internal cross section of no less than 320cm² (200mm dia). If a flue liner is used it should be 5" diameter (125mm) and suitable for solid fuel.
- Be a minimum 4.6m high from hearth level to pot.
- Be terminated at least 1m above roof level so that the chimney does not terminate in a pressure zone (see Fig.2).
- Be free from cracks, severe bends, voids and obstructions.
- Be connected to this one appliance only.
- New chimneys must be tested in accordance with HETAS requirements.
- If this stove is installed as a freestanding appliance, it should not support any part of the chimney.
- Voids in the chimney should be avoided, as these will prevent a steady flue draught.
- The stove flue pipe should pass beyond the narrowing of the chimney (see Fig. 1).
- Consideration should be given to falling soot. For rear outlet stoves it may be necessary to provide a soot catchment area in the flue pipe so that soot does not settle in the path of the flue gases. The optional rear flue box attachment available from Dimplex has a detachable base that allows for fallen soot to be removed (See Fig.1).
- A flue/chimney access point may also be required so that the state of the chimney can be checked and any fallen soot removed.
- External flue must be insulated to prevent heat loss.

Fig. 1 – Ideal Flue Connections.

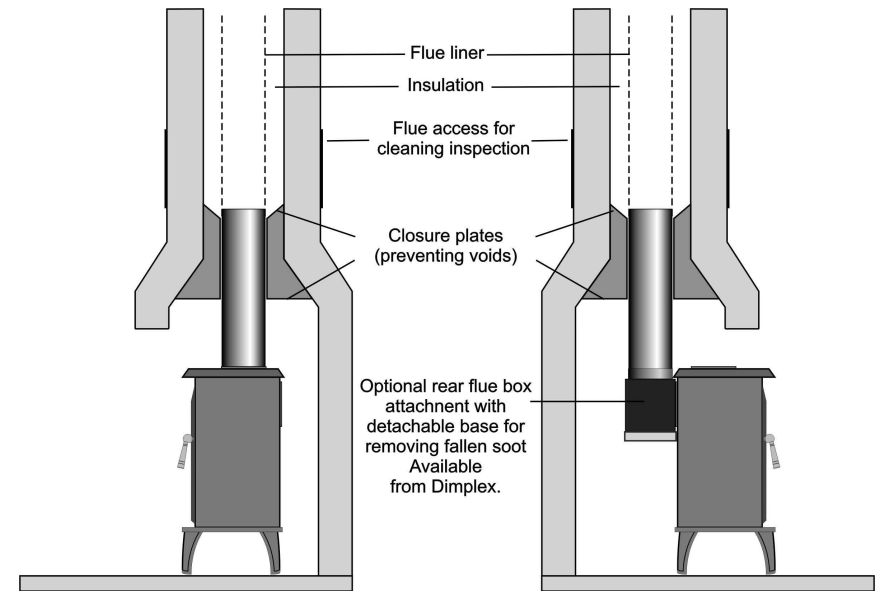
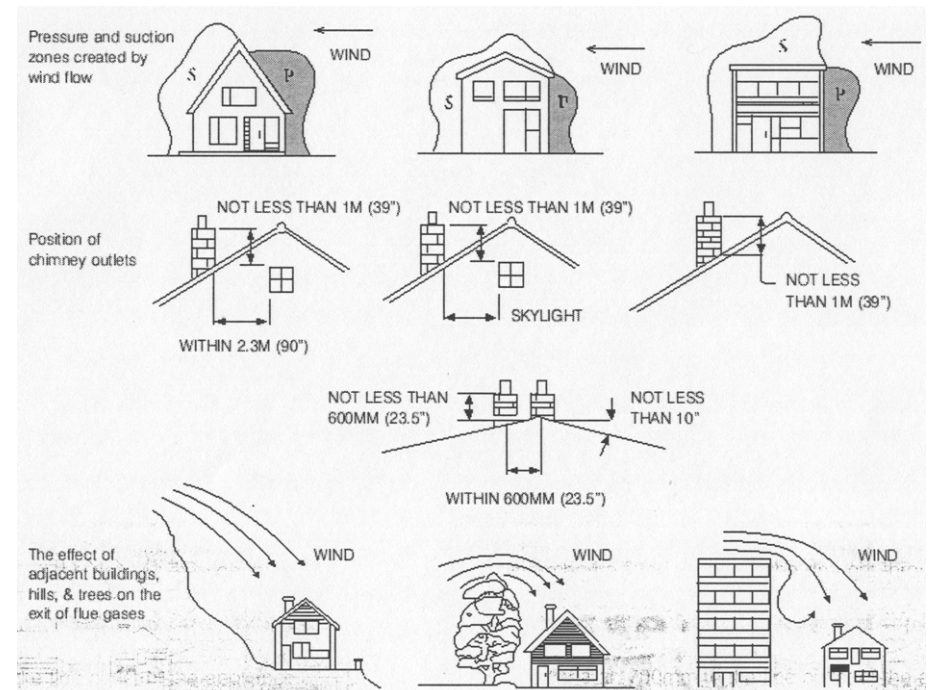

Fig.2 – Chimney and Flue Performance



FLUE DRAUGHT

The chimney can be checked, before the stove is installed, with a smoke match. If the chimney doesn't pull the smoke it may suggest the chimney needs attention (see the Flue Diagnosis Table, below).

MEASUREMENTS

The flue draught test hole must be drilled in the flue pipe as close to the stove as possible and before any flue draught stabiliser.

Note: This test is only a guide as an apparently poor flue may improve once the stove is installed, lit and the flue is warmed. If, once the stove is installed, there is any doubt that the chimney is providing an adequate draught, a flue draught reading can be taken with the stove lit. Two flue draught readings should be taken, one with the stove at minimum firing rate and one at maximum firing rate.

MINIMUM

The stove should be lit and allowed to warm the flue thoroughly. The air controls can then be set so that the stove burns on a low setting. Allow the burning rate to become steady. The flue draught reading should now be taken with the primary air intake closed and the airwash control fully open.

MAXIMUM

The primary air intake can now be opened to allow the stove to burn at maximum rate. Give the stove some time for the burning rate to become steady and then close the primary air intake, make sure the airwash control is fully open and take a flue draught reading immediately.

Ideally, the flue draught reading should range between 1mm wg (10 Pa) and 2.5mm wg (25 Pa). Any readings significantly outside this range may indicate the need for remedial action.

Low flue draught symptoms: *difficult to light and smoke coming into the room.*

| CAUSE | REMEDY |
|----------------------------|--|
| Cold chimney | <i>Line the chimney</i> |
| Chimney too short | <i>Extend the chimney</i> |
| Down draught | <i>Relocate/extend chimney terminal. Fit an anti down draught cowl</i> |
| Chimney diameter too large | <i>Line the chimney</i> |
| Chimney obstruction | <i>Clear/sweep the chimney</i> |
| Restricted air supply | <i>Check for competing draughts (other chimneys, extractor hoods/fans). Fit an air vent if the room is sealed.</i> |

High flue draught symptoms: *fire difficult to control, fuel will not last, stove too hot, stove damage, chimney fire.*

| CAUSE | REMEDY |
|---|--|
| External wind conditions combined with chimney terminal | <i>Fit stabiliser cowl. Fit flue draught stabiliser.</i> |

FLUE STABILISER

A flue stabiliser can be fitted to reduce the draught through the stove if the flue draught is too high. The flue stabiliser should be:

- Fitted in the same room as the stove
- The same size as the flue pipe
- Fitted no closer than 700mm to the flue outlet of the appliance.

DIMENSIONS & CLEARANCES (all measurements are in mm)

Fig. 3

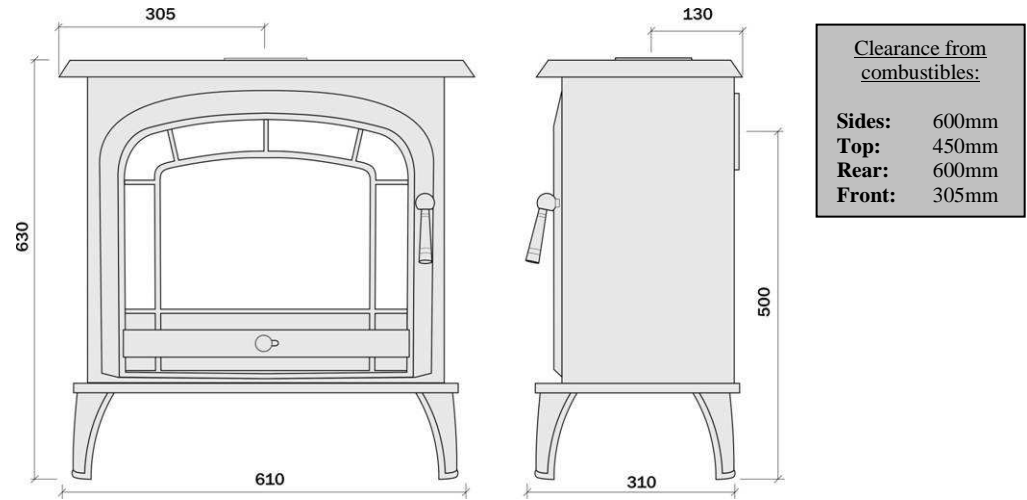

INSTALLING THE STOVE

POSITIONING

The overall dimensions of the stove are shown in Fig. 3. The table above indicates recommended distances between the stove and surrounding combustible materials. As a rule, any surrounding combustible material should not exceed 80 °C. There should be sufficient space around the stove for service work.

HEARTH

The construction of the hearth must conform to Building Regulations, must be firm, non-combustible and capable of supporting the stove. (Refer to Building Regulations Document J).

FLUE CONNECTION

The flue pipe used to connect the stove to the chimney is 5" (125mm) in diameter. The stove is supplied ready for top flue connection. To change to rear connection the flue blanking plug supplied with the stove is used to block the top flue outlet. The blanking plug in the rear flue connection must then be removed (to access the bolts attaching the rear flue connection the convector panel must first be removed) – see Fig.4. A rear flue box attachment is also available from Dimplex that allows the stove to be installed further out of any building recess. Fig.1 shows suitable flue connections.

IMPORTANT INSTALLATION NOTES:

1. The installation must allow for adequate chimney sweeping.
2. Avoid using bends greater than 45 °C to the vertical. All flue pipe sections should be as close to vertical as possible.
3. All joints in the flue system must be effectively sealed.
4. All flue sockets must face upwards.
5. Check the appliance for sound of seals between castings and main components and that all supplied parts and fitting are correctly fitted.

On completing the installation, check that all the internal components of the stove are positioned correctly. Check – ashpan, iron grate, baffle, side and back bricks.

Fig. 4 – Arranging the flue outlet blanking plug for top or rear outlet

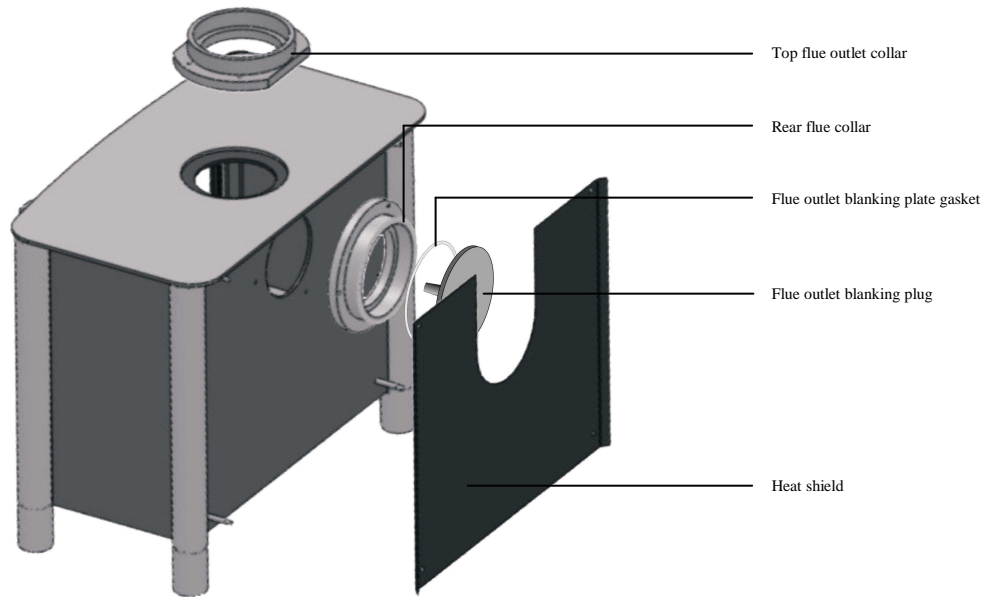
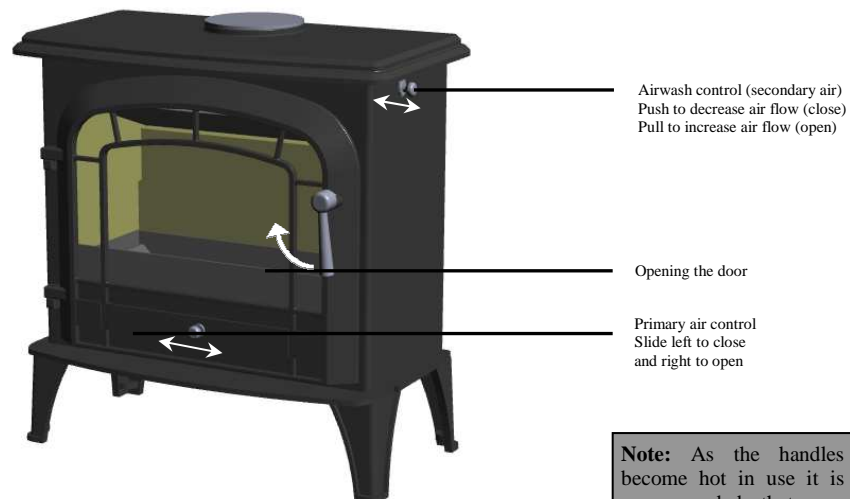

Fig. 5 – Operating your stove



Note: As the handles become hot in use it is recommended that you use the stove mitt supplied.

OPERATING INSTRUCTIONS

YOUR STOVE

Fig. 5 shows stove and its controls.

Additional loose parts supplied inside your stove include:

- A stove mitt – for removing the ash pan, adjusting the primary air controls, adjusting the airwash control, and operating the door handle. Fig.5 shows how the stove mitt is used.
- A flue blanking plug to blank the top flue outlet if the rear flue outlet is to be used.

WOODBURNING

LIGHTING & CONTROLLING THE FIRE

Before lighting the fire for the first time ensure that the baffle, side and back bricks and all the internal components are in position. Burning without either will result in the stove overheating and being damaged.

Open the air wash control and the primary air control fully. Place some tightly rolled paper on top of some crumpled paper on the base towards the back of the stove. On top of this, place some small pieces of wood. Light the crumpled paper and close the door. Once the fire becomes established add some larger pieces of wood. As the stove comes up to temperature close the primary air control using the stove mitt as shown in Fig.5. The burning rate of the stove can now be regulated by the rate at which fuel is added and by adjusting the air wash control.

With the above in mind it is plain to see that the stove should ideally be run with the primary air inlet closed and the air wash control open whenever possible. Another advantage of running the stove with the air wash open is that the air is being drawn into the stove travels across the glass forming an air barrier between the glass and the fire bed helping to prevent smoke particle sticking to the glass.

If the fire dies down too low, opening the primary air control for a short period will revive it. When reviving a low fire it is important to also use kindling before adding larger logs to help prevent smoke.

Note: Wood burns most efficiently when the air for combustion is supplied from above the fire bed rather than below. The air supplied above the fire bed provides the oxygen necessary for the volatile gases (smoke), given off by the wood as it heats to combust. This ensures that the gases are burnt and used to heat the stove instead of being wasted up the chimney or condensing and forming tarry deposits inside the stove, in the flue or on the stove glass. Running the stove with the primary air control open and the air wash control closed will provide oxygen for the wood to burn on the fire bed but will not provide air for the volatile gases above the fire bed to combust resulting in a smoky inefficient fire.

ASH REMOVAL

Only remove small amounts of ash from the firebox. When de-ashing, leave 30-40mm depth of ash in the bottom of the firebox for the best performance. Always use the stove mitt to open and close the door.

CORRECT RUNNING TEMPERATURE FOR BURNING

To get the best results from your stove it is recommended that a wood stove thermometer (available from your stove dealer) be fitted to the flue pipe above the stove, at eye level if possible. The figures below show the recommended temperature of the flue gases:

115°C – 245°C (240°F - 475°F)

The flue gases should be in this temperature band for the safest, most efficient and most economical operation of your stove.

Below 115°C

This is below the condensation point of wood gases and may cause the build up of tar in the chimney, dirty the stove glass and result in the inefficient burning of fuel.

Above 245°C

Too hot. Heat will be wasted up the chimney. Excess heat may damage the stove or ignite any existing accumulation of tar resulting in a chimney fire.

EXTENDED BURNING

Loading a large amount of wood into the stove all at once will reduce the temperature inside the stove. If the temperature is too low, the gases given off from the wood will be too low to combust resulting in a lot of smoke covering the inside of the stove, including the glass, with soot. To combat this problem it is a good idea to increase the temperature of the stove before loading by further opening the air inlets. Load the wood and leave the air controls open until the moisture is driven out of the wood and the stove is back up to an efficient operating temperature. The air inlets can then be reduced to hold the temperature of the stove. Loading the stove little and often will help keep the stove temperature steady. When loading wood, make sure that the end grain of the wood in the stove is pointing away from the glass, otherwise the moisture and gases coming from the end grain of the wood will dirty the glass.

TYPES OF WOOD FOR FUEL

For best results use well seasoned hardwood such as Oak, Ash, or Beech. Allow wood to dry out under cover in well-ventilated conditions for at least twelve months. As a rough guide wood is ready for burning when radial cracks appear in the end of the logs. Properly dry wood means it should have a moisture content of less than 20% which can only be accurately measured using a moisture meter. Burning wood that is not seasoned will result in tar being deposited in the stove, on the glass and in the flueways. This build up of tar is a hazard and if it ignites may cause a chimney fire. Resinous softwood burns well and gives a high output for short periods but is not as efficient and does not last as long as hardwood.

RE-FUELLING

Adding a 'little fuel often' is the best re-fuelling method to keep smoke to a minimum. Our tests have shown that burning logs not longer than 20cm and with a width or diameter of no more than 12cm will produce the optimum smoke free performance.

Note: The above text should be used as a guide only. The ideal operation of your stove depends on a number of factors, which vary with each installation, and so gaining experience operating your stove is the only way to learn its best operation.

Note: Your stove should not be used as an incinerator and non recommended fuels shall not be used.

Note: The stove as with any other metal product will expand and contract. A ticking noise may occur. This is normal for this type of appliance.

MAINTENANCE

CLEANING THE STOVE

The stove should only be cleaned when it is cold. The exterior can be dusted with a firm brush. Do not use a cloth, as this will drag on the paint finish leaving lint on the surface. From time to time it may be necessary to renovate the exterior by repainting. High temperature stove paints in aerosol form are available from your stove dealer. Do not use this form of paint until the stove is cold and always read the instructions on the container before starting to paint. The door glass is made of a special heat resisting ceramic and may be cleaned when cold with proprietary glass cleaning liquids and a dry cloth.

SHUTTING DOWN THE STOVE (LONG TERM)

The following procedure should be followed if the stove is not to be used for a long period, summertime for instance. Remove all the ashes from the grate and ash pan and use a vacuum cleaner nozzle to clean ash from the base of the stove. Remove the baffle plate and brush the flue ways. Close the door and open the air inlets fully. This action will allow air circulation through the flue ways and help to avoid corrosion and condensation.

SERVICING

Regular maintenance should be carried out by a competent engineer.

TECHNICAL INFORMATION

| | |
|----------------------------------|---------|
| Normal heat output – wood | 5.0 kW |
| Weight of stove | 83.6 kg |
| Minimum chimney draught | 10 Pa |
| Mean flue gas temperature – wood | 244 °C |
| Flue gas mass flow - wood | 3.1 g/s |

This appliance is not suitable for installation in a shared flue system.

