

Danube Portastove Model: DNB20
Lagan Portastove Model: LAG20
Elba Portastove Model: ELB20
Allegri Portastove Model: ALG20

08/18796/5 Issue 5

Dimensions (millimetres)

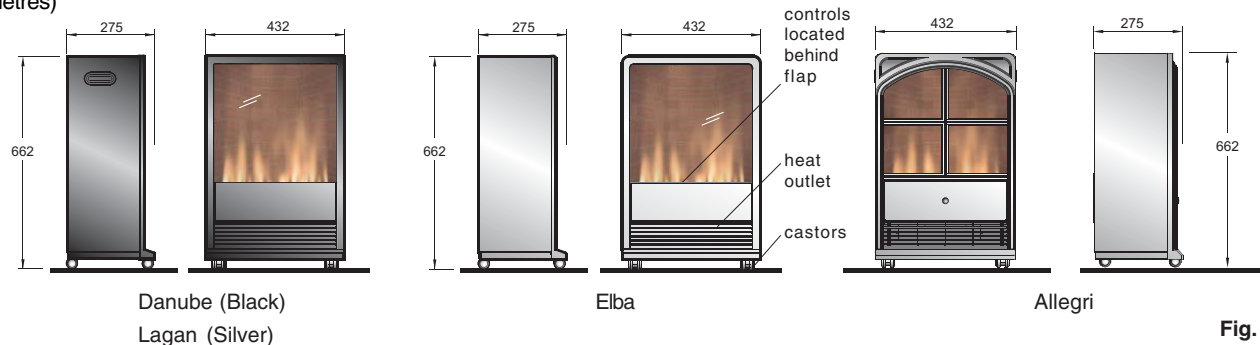

Fig. 1

IMPORTANT: THESE INSTRUCTIONS SHOULD BE READ CAREFULLY AND RETAINED FOR FUTURE REFERENCE

Important Safety Advice

When using electrical appliances, basic precautions should always be followed to reduce the risk of fire, electrical shock, and injury to persons, including the following:

If the appliance is damaged, check with the supplier before installation and operation.

Do not use outdoors.

Do not use in the immediate surroundings of a bath, shower or swimming pool.

Do not locate the heater immediately below a fixed socket outlet or connection box.

Do not cover the heater. Do not place material or garments on the heater, or obstruct the air circulation around the heater, for instance by curtains or furniture, as this could cause overheating and a fire risk.

This appliance is not intended for use by children or other persons without assistance or supervision if their physical, sensory or mental capabilities prevent them from using it safely. Children should be supervised to ensure that they do not play with the appliance.

WARNING: In order to avoid a hazard due to inadvertent resetting of the thermal cut-out, this appliance must not be supplied through an external switching device, such as a timer, or connected to a circuit that is regularly switched on and off by the utility.

Ensure that furniture, curtains or other combustible material are positioned no closer than 1 metre from the heater.

In the event of a fault unplug the heater.

Unplug the heater when not required for long periods.

Although this heater complies with safety standards, we do not recommend its use on deep pile carpets or on long hair type of rugs.

The appliance must be positioned so that the plug is accessible.

If the supply cord is damaged it must be replaced by the manufacturer or service agent or a similarly qualified person in order to avoid a hazard.

Keep the supply cord away from the front of the heater.

Introduction

Unpack the heater carefully and retain the packaging for possible future use, in the event of moving or returning the fire to your supplier.

These models are fitted with castors and handles so they can be moved from room to room with ease, and are normally positioned against a wall.

A choice of 1kW or 2kW heat output is provided by the fan heater, which is located at the bottom of the unit.

Before connecting the heater check that the supply voltage is the same as that stated on the heater.

Please note: Used in an environment where background noise is very low, it may be possible to hear a sound which is related to the operation of the flame effect. This is normal and should not be a cause for concern.

Electrical connection

WARNING – THIS APPLIANCE MUST BE EARTHED

This heater must be used on an AC ~ supply only and the voltage marked on the heater must correspond to the supply voltage.

Before switching on, please read the safety warnings and operating instructions.

In the event of replacing the fuse in the plug supplied, a 13 amp fuse approved by ASTA to BS1362 must be used.

Operation

The unique flame effect may be enjoyed whether or not the heating elements are in operation.

Controls

The heater controls are located behind the flap on the front of the heater. (see Fig. 1).

Three switches provide a choice of heat settings. A switch is in the ON position when the side with the markings on (i.e. I, II, or III) is pushed in.

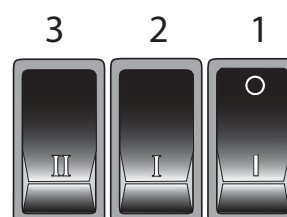

Fig. 2

Switch 1 (I) Controls the electricity supply to the heater and flame effect

Note: This switch must be in the ON (I) position for heater to operate with or without heat

Switch 2 (I) Provides 1kW heat output

Switch 3 (II) Provides 2kW output with switch 2

Maintenance

WARNING – BEFORE UNDERTAKING ANY MAINTENANCE OR CLEANING REMOVE PLUG OR DISCONNECT FROM THE ELECTRICITY SUPPLY.

Lamp Replacement

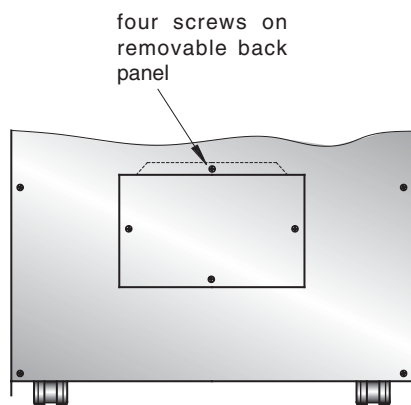

Fig. 3

Two lamps are located behind the back panel as indicated in Fig. 3. To gain access to the lamps, the four screws which secure the back panel, must be removed. Remove and slide out panel as indicated in Fig. 4.

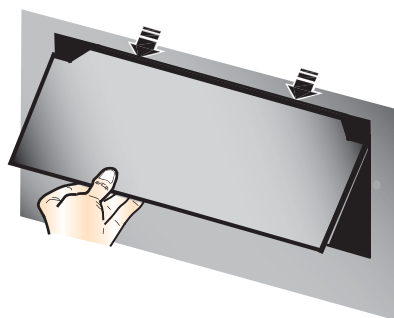

Fig. 4

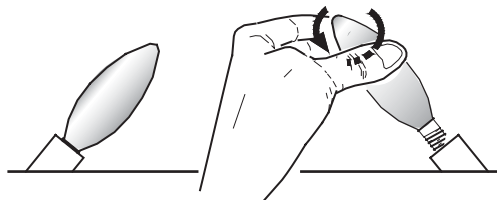

Fig. 5

Remove the defective lamp by unscrewing it as shown -see Fig. 5. Replace with a 60W E14 SES Clear Candle lamp.

Take care not to over-tighten the lamp. Refit the back panel and secure with the four screws.

Thermal Safety Cut-out

The built-in overheat cut-out switches of the appliance automatically in the event of a fault. Switch off the appliance or disconnect the mains plug from the socket. After a short cooling down phase, the appliance is ready for use again. If the fault should occur again, see your local dealer.

WARNING: In order to avoid a hazard due to inadvertent resetting of the thermal cut-out, this appliance must not be supplied through an external switching device, such as a timer, or connected to a circuit that is regularly switched on and off by the utility.

Recycling

For electrical products sold within the European Community.



At the end of the electrical products useful life it should not be disposed of with household waste. Please recycle where facilities exist. Check with your Local Authority or retailer for recycling advice in your country.

Cleaning

For general cleaning use a soft clean duster – never use abrasive cleaners. The viewing screen should be cleaned carefully with a soft cloth. DO NOT use proprietary glass cleaners.

After Sales Service

Your product is guaranteed for one year from the date of purchase.

Within this period, we undertake to repair or exchange this product free of charge (excluding lamps & subject to availability) provided it has been installed and operated in accordance with these instructions.

Your rights under this guarantee are additional to your statutory rights, which in turn are not affected by this guarantee.

Should you require after sales information or assistance with this product please go to www.dimplex.co.uk where you will find our self help guide by clicking on “After Sales” or ring our helpdesk on 0845 600 5111 (UK) or 01 842 4833 (R.O.I.) .

Spare parts are also available on the website

www.dimplex.co.uk

Please retain your receipt as proof of purchase.



The product complies with the European Safety Standards EN60335-2-30 and the European Standard Electromagnetic Compatibility (EMC) EN55014, EN60555-2 and EN60555-3. These cover the essential requirements of EEC Directives 2006/95/EC and 2004/108/EC

Dimplex UK Ltd.
Millbrook House
Grange Drive
Hedge End
Southampton
Hampshire. SO30 2DF
[c] Dimplex UK Limited

www.dimplex.co.uk

Republic of Ireland Tel. 01 8424833

All rights reserved. Material contained in this publication may not be reproduced in whole or in part, without prior permission in writing of Dimplex UK Limited.