

Dimplex

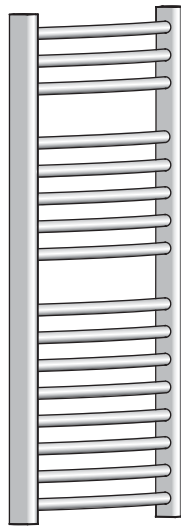

SLR 200WE & SLR 200CE

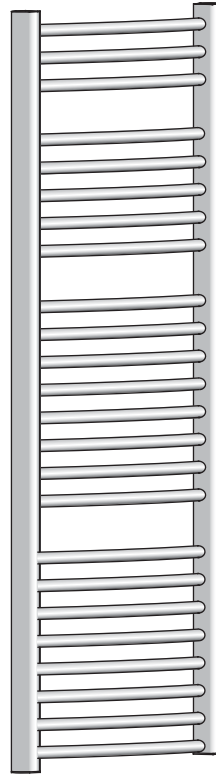

SLR 400WE & SLR 400CE



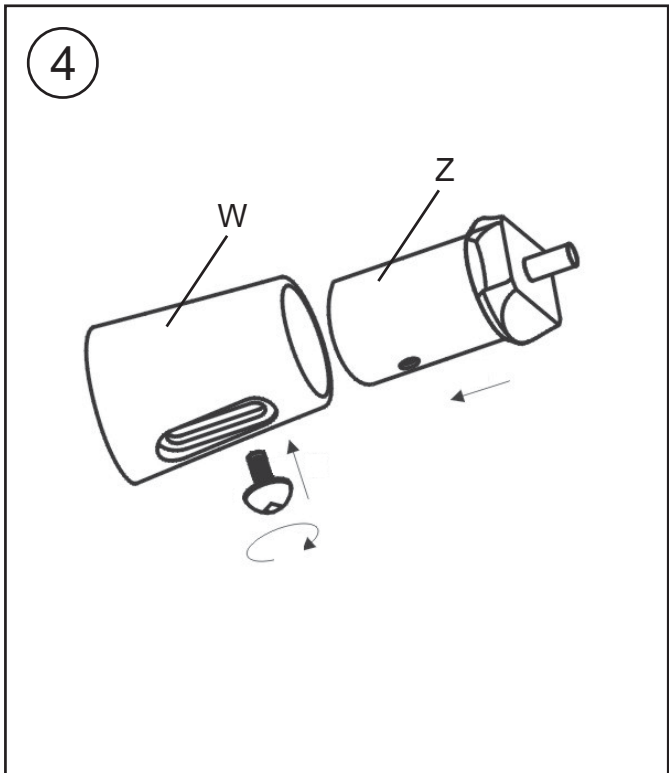
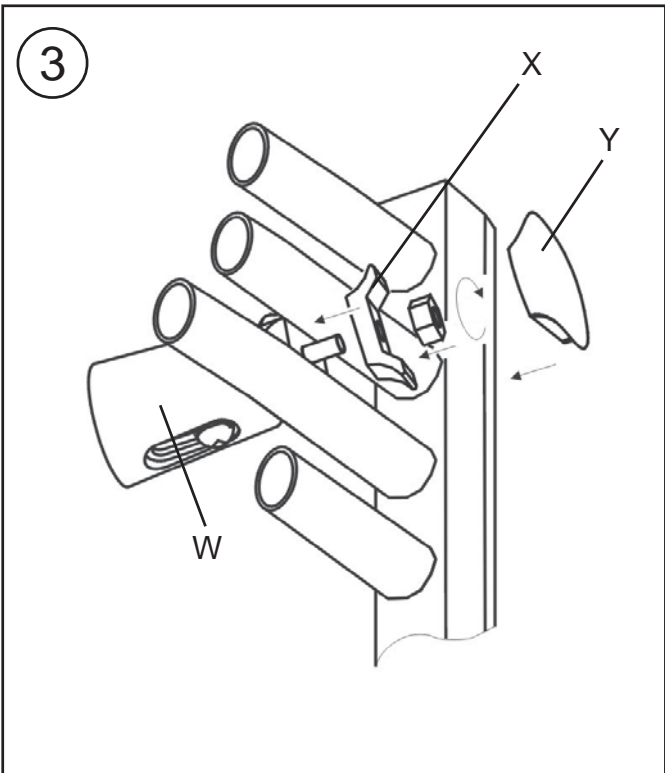
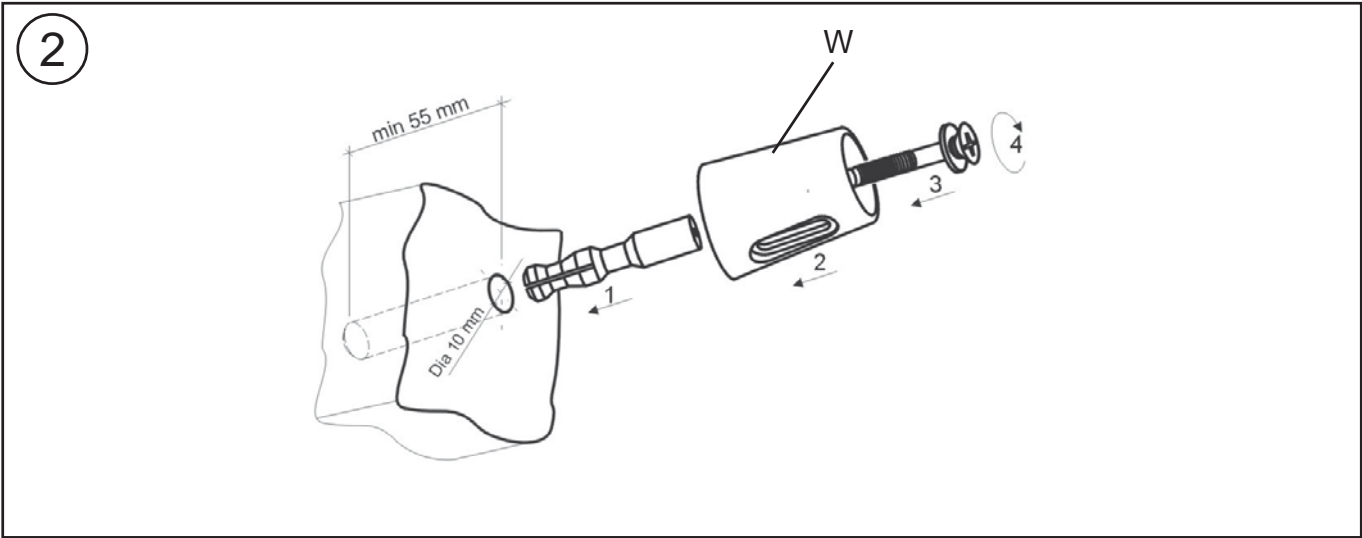
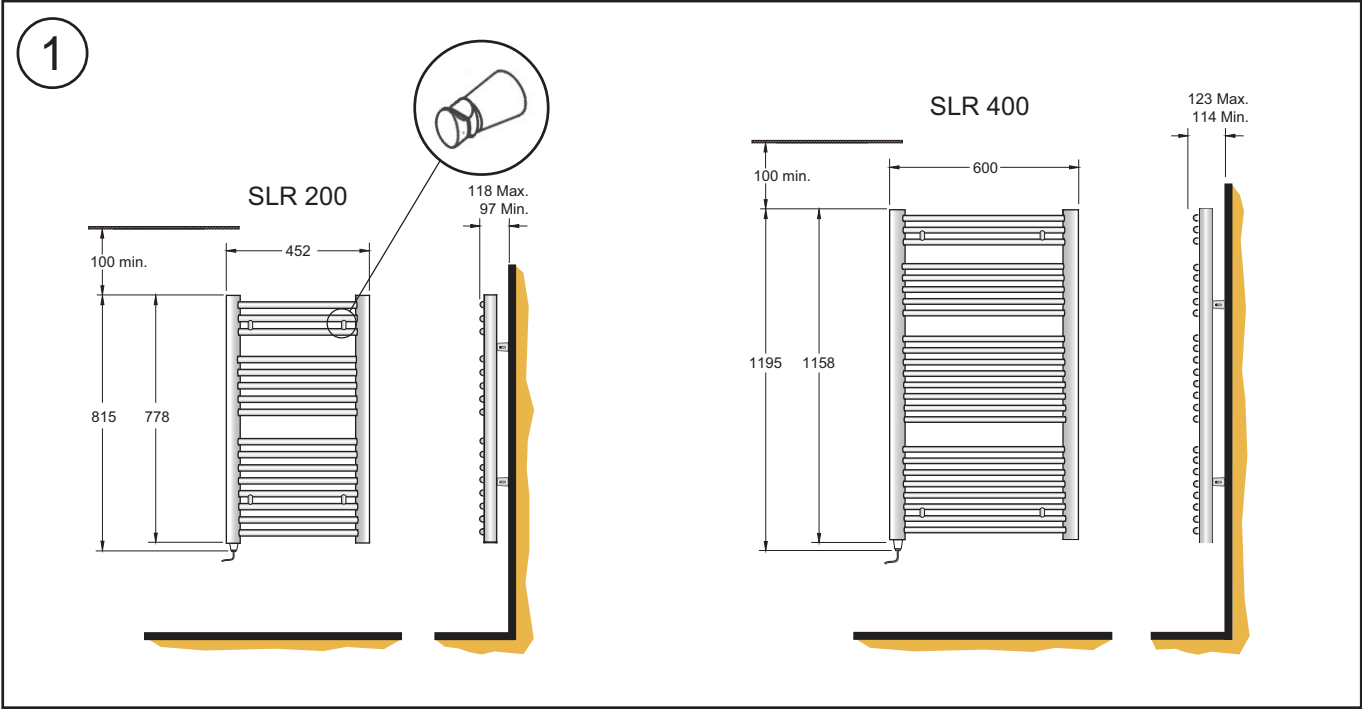

SLR Towel Rails

Models : SLR200WE, SLR200CE, SLR400WE & SLR400CE

IMPORTANT : THESE INSTRUCTIONS SHOULD BE READ CAREFULLY AND RETAINED FOR FUTURE REFERENCE

Table1

Model	Rails	Watts	Weight (kg)
SLR200 WE/CE	16	200	9.5
SLR400 WE/CE	24	400	16.9

Important Safety Advice

WARNING - THE SURFACE OF THIS RADIATOR CAN BE HOT.

In order to be effective the towel rail will get hot, however momentary contact with any part of it should not cause injury.

CAUTION - This appliance is not intended for use by children or other persons without assistance or supervision if their physical, sensory or mental capabilities prevent them from using it safely. Children should be supervised to ensure that they do not play with the appliance.

Precautions should be taken to ensure that prolonged contact with the towel rail cannot occur. Particular care should be taken in confined areas where accidental prolonged contact with the rail could be more likely to occur.

This appliance should only be used to dry fabrics washed in water using commonly available detergents.

IMPORTANT - If the towel rail is to be installed in a place used by the public, a warning notice should be placed adjacent to the rail advising that the surface can be hot.

WARNING - In order to avoid a hazard for very young children, this appliance should be installed so that the lowest heated rail is at least 600mm above the floor.

General

The SLR towel rail is designed to provide an all year round service for airing towels and articles of clothing. It will also provide heat for bathrooms and other small rooms. The towel rail is permanently filled with a special water based liquid for years of trouble free service. No routine maintenance is necessary apart from occasional cleaning.

The towel rail has a sealed electrical element controlled by a pre-set thermostat which will switch off the rail should it overheat for any reason. It is splashproof to IPX4 standard.

Electrical

The electrical installation of this towel rail must be carried out by a competent electrician in accordance with the current I.E.E Regulations for Electrical Equipment. The towel rail is suitable for use on an A.C.~ electrical supply. Before installation check that the supply voltage corresponds with that marked on the rail.

WARNING - THIS APPLIANCE MUST BE EARTHED.

IMPORTANT - The wires in the mains lead are coloured in accordance with the following code:

GREEN and YELLOW	- EARTH
BLUE	- NEUTRAL
BROWN	- LIVE

As the colours of the wires in the mains lead of this appliance may not correspond with the coloured markings identifying the terminals in your plug, proceed as follows:

The wire which is coloured GREEN and YELLOW must be connected to the terminal in the plug which is marked with the letter

E or by the earth symbol  or coloured green or green and yellow.

The wire which is coloured BLUE must be connected to the terminal which is marked with the letter **N** or coloured black.

The wire which is coloured BROWN must be connected to the terminal which is marked with the letter **L** or coloured red.

This appliance must only be used on A.C. mains supply of 230/240 Volts~.

Installation

If fitted in a room containing a bath or shower, to comply with the current I.E.E. Regulations, a cable outlet will be necessary with the supply to the heater controlled by a double-pole pull-cord switch having a contact separation of 3mm in each pole. The body of the switch should be situated as to be normally inaccessible to a person using a bath or shower. Should Equipotential Earth Bonding be required the earthing conductor in the supply cord is deemed to provide the supplementary bonding connection (see Regulation 547-03-0, '16th' Edition I.E.E. Wiring Regulations).

IMPORTANT - Protect the electrical connection whilst handling the towel rail.

The towel rail must be permanently fixed to the wall using the wall brackets supplied. The rail must be mounted vertically as shown observing the minimum clearances stated.

WARNING - The towel rail is heavy. Care must be taken when lifting and fitting the towel rail.

Wall mounting

The Wall mounting accessory pack (see Fig. 2) contains:

- 4 mounting brackets
- 1 allen key
- 4 wall mounting screws, washers and wall plugs
- 4 hex. stud screws

Procedure for wall mounting

Step 1

Mark suitable hole positions for the four fixing brackets (ensuring they are horizontal). Drill and plug the wall to suit - see Fig. 2.

Note: Allow enough room above and below for the clearance stated and suggested wall brackets positions - see Fig. 1.

Step 2

The hex. stud screw in the slot has to be removed using the allen key provided first, to separate the inner 'Z' and outer 'W' sleeves of the wall brackets.

Mount the four outer sleeve wall brackets in line with the drilled out holes using the screws provided - see steps 1 - 4 in Fig. 2.

Note: the brackets have slot holes to allow for possible adjustment later.

Step 3

Remove the cap 'Y' from the inner sleeve assembly, unscrew the nut and remove the rail support 'X'. On the inner side (wall) of the towel rail position the inner sleeve between the cross rails as indicated in Fig. 1. Position the rail support to receive the bolt on the inner sleeve and hand tighten with the nut - see Fig. 3.

Slide into position (see suggested positions in Fig. 1).

Step 4

Lift the towel rail now with the inner sleeve assembly in position, and align with the outer sleeve previously fixed to the wall. When all four inner sleeves are inserted correctly into the outer sleeves of the brackets tighten each nut fully. Replace the cap 'Y' and the hex. stud screw. The distance the towel rail can be positioned from the wall can be varied by adjusting the hex. stud screws. When in the desired location, tighten fully to secure the towel rail to the wall.

To assist with the alignment of the outer 'W' and inner 'Z' sleeves the outer sleeve may be adjusted using the slot provided, refer to Note in step 2.

Drying and Airing Towels

It is recommended that for efficient drying, no more than two layers of towels or similar fabric should be draped over the rail. Items should be placed evenly over the whole surface of the rail where possible.

It is not advisable to leave very damp towels or clothes on the towel rail when not in use, as this may in time, affect the paint finish.

The rail, although hot to the touch is not hot enough to scorch or burn fabrics. However, soap and detergents remaining in articles after washing can cause discoloration. Therefore care should be taken to thoroughly rinse articles before airing.

Important Safeguards

WARNING - The towel rail is filled with an anti-freeze/water solution. The following precautions should be followed when handling and disposing of the liquid.

- Avoid skin and eye contact. Wear protective gloves and goggles.
- Do not swallow.
- Keep out of reach of children.
- Keep away from pets.
- Do not empty into drains or watercourses.
- Dispose of it at an authorised disposal facility.

Operation (Electrical)

It is a feature of the product that the bottom rails remains cool to the touch. Some variation in the temperature across the surface of the rail is also normal. When the appliance is covered the heating pattern of the rails may alter, and generally temperatures at the upper part of that rail will rise

The towel rail may be switched on and off at the isolating wall switch which must be positioned outside the bathroom, or operated by means of a pull cord switch.

Note: If the towel rail is located in a bathroom the adjustment for these controls must be located outside the bathroom.

Maintenance

There are no user serviceable parts on the towel rail.

The rail is filled with a precise quantity of special liquid and for electric only operation should never need draining or refilling. Repairs requiring the opening of the liquid-tight seal must only be made by the manufacturer's Service Agent. Any leakage must be reported to the manufacturer's Service Agent.

The element and cable are a single unit and any maintenance must be carried out by the manufacturers service agent using the recommended parts Ref. Numbers SLR200 - **TR20001** and SLR400 - **TR9901**.

Cleaning

The finish on your towel rail can be maintained by occasionally wiping over with a damp cloth and lightly finishing with a soft dry cloth. This should only be carried out when the rail is cold. **Do not** use abrasive cleaning powders as this could damage the surface finish.

Recycling

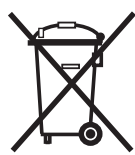

For electrical products sold within the European Community.

At the end of the electrical products useful life it should not be disposed of with household waste. Please recycle where facilities exist. Check with your Local Authority or retailer for recycling advice in your country.

After Sales Service

Your product is guaranteed for two years from the date of purchase.

Within this period, we undertake to repair or exchange this product free of charge (subject to availability) provided it has been installed and operated in accordance with these instructions.

Your rights under this guarantee are additional to your statutory rights, which in turn are not affected by this guarantee.

Should you require after sales service you should contact our customer services help desk on 0845 600 5111. It would assist us if you can quote the model number, series, date of purchase, and nature of the fault at the time of your call. The customer services help desk will also be able to advise you should you need to purchase any spares.

Please do not return a faulty product to us in the first instance as this may result in loss or damage and delay in providing you with a satisfactory service.

Please retain your receipt as proof of purchase.

Dimplex UK Limited
Millbrook House
Grange Drive
Hedge End
Southampton
Hampshire. SO30 2DF

UK customer help line 8.00am–5.00pm Mon-Fri and 8:30am-1.00pm Sat (October-March)

Technical Services: Tel. 0845 600 5111
Fax. 01489 773053
e-mail technical.services@dimplex.co.uk
Republic of Ireland Tel. 01 8424833