

Dimplex

Installation and Operating Instructions

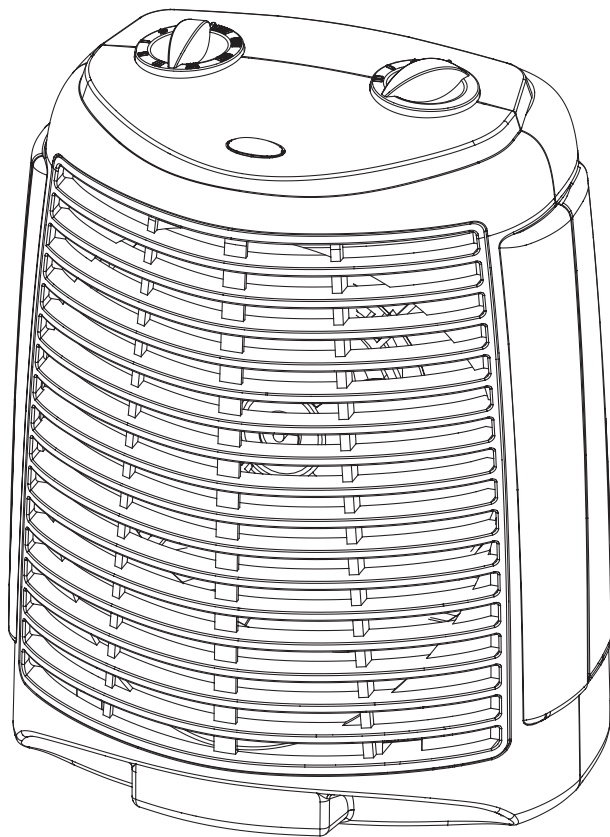

DEUF2

08/51929/0 Issue 6

As with all portable heating appliances: This product is suitable only for well insulated spaces or occasional use.

 The product complies with the European Safety Standards EN60335:2-30 and the European Standard Electromagnetic Compatibility (EMC) EN55014:1, EN55014:2, EN61000:3-2 and EN61000:3-3 which cover the essential requirements of EMC Directive 2014/30/EU and the LVD Directive 2014/35/EU.

Fan Heaters

Model(s) : DEUF2

Dimensions	H	W	D
(millimetres)	241	212	166

Model(s) Specification

DEUF2 2.0kW Thermostat & Switch

IMPORTANT : THESE INSTRUCTIONS SHOULD BE READ CAREFULLY AND RETAINED FOR FUTURE REFERENCE

IMPORTANT SAFETY ADVICE

READ THESE INSTRUCTIONS BEFORE USE.

DO NOT use the heater on deep pile carpets or the long hair type of rugs, or less than 750mm (30") away from any overhanging surface. Keep combustible materials such as drapes and other furnishings clear from the front, sides and rear of the heater. Do not use heater to dry your laundry.

DO NOT use the heater in the immediate surroundings of a bath, a shower or a swimming pool.

DO NOT place the heater directly below a fixed socket outlet.

The socket-outlet must be accessible at all times to enable the mains plug to be disconnected as quickly as possible.

DO NOT COVER or obstruct the air inlet and outlet openings in any way.

The heater must be on a flat stable surface when in use.

DO NOT operate the heater with the mains lead overhanging the front outlet grille.



The heater carries the warning symbol to indicate that it must not be covered.

WARNING: In order to avoid overheating do not cover the heater.

The instruction leaflet belongs to the appliance and must be kept in a safe place. If changing owners, the leaflet must be surrendered to the new owner.

WARNING: To avoid danger of suffocation please remove all packaging materials particularly plastic and EPS and keep these away from vulnerable people, children and babies.

WARNING: To avoid the risk of accidental strangulation from the supply cord all children and vulnerable people must be supervised when in the vicinity of the product whether it is working or not.

IMPORTANT: If the mains lead of this appliance is damaged, it must be replaced by the manufacturer or its service agent or a similarly qualified person in order to avoid a hazard.

WARNING: In order to avoid a hazard due to inadvertent resetting of the thermal cut-out, this appliance must not be supplied through an external switching device, such as a timer, or connected to a circuit that is regularly switched on and off by the utility.

This appliance can be used by children aged from 8 years and above and persons with reduced physical, sensory or mental capabilities or lack of experience or knowledge if they have been given supervision or instruction concerning the use of the appliance in a safe way and understand the hazards involved. Children shall not play with the appliance. Cleaning and user maintenance shall not be made by children without supervision.

Children of less than 3 years should be kept away unless continuously supervised. Children aged from 3 years and less than 8 years shall only switch on/off the appliance provided that it has been placed or installed in its intended normal operating position and they have been given supervision or instruction concerning the use of the appliance in a safe way and understand the hazards involved. Children aged from 3 years and less than 8 years shall not plug in, regulate and clean the appliance or perform user maintenance.

CAUTION: Some parts of this product can become very hot and cause burns. Particular attention has to be given where children and vulnerable people are present.

Avoid use of an extension cord because the extension cord may overheat and cause risk of fire.

Electrical connection

This heater must be used on an **A.C.~** supply only and the voltage marked on the heater must correspond to the supply voltage. This heater is fitted with a plug incorporating a 13 amp fuse. When replacing the fuse, a 13 amp fuse approved by ASTA to BS 1362 must be used.

If the plug is not suitable for the socket outlets in your home, the plug must be cut off and an appropriate one fitted. A plug cut off from a mains lead will give a shock hazard if inserted into a 13 amp socket elsewhere in the house. To avoid this, it should be disposed of immediately.

NOTE: The fuse cover of a non-rewirable plug must be refitted when changing the fuse. Should the cover become lost, the plug must not be used until the correct replacement fuse cover is obtained from your supplier or by contacting our customer helpline.

IMPORTANT : The wires in this mains lead are coloured in accordance with the following code :

BLUE : NEUTRAL
BROWN : LIVE

As the colours of the wires in the mains lead may not correspond with the coloured markings in your plug, proceed as follows :

Connect the **BROWN** wire to the terminal marked 'L' or coloured **RED**. Connect the **BLUE** wire to the terminal marked 'N' or coloured **BLACK**. **Note :** 'L' or 'N' must not be connected to the **EARTH** terminal marked 'E' or '⊕' or coloured **GREEN** or **GREEN AND YELLOW**.

If in doubt, consult your electrician.

Using the Heater

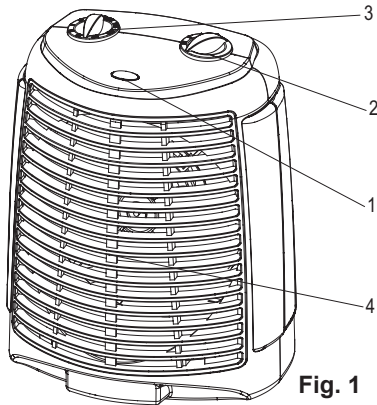

Fig. 1

Main Elements - See Fig 1.

1. Power Indicator Light
2. Thermostat Control Knob
3. Switch Knob
4. Air Outlet

Heat Control - see Fig. 1.2

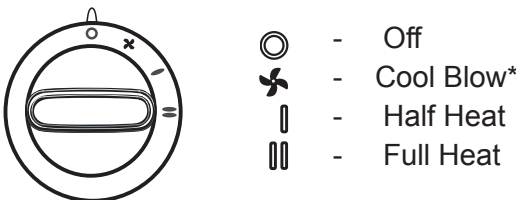

Fig. 1.2

Thermostat Control - see Fig. 1.3

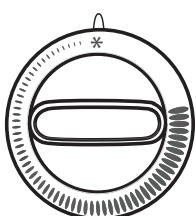



Fig. 1.3

The heat output is controlled by the thermostat, according to the room temperature.

Turn the thermostat knob fully clockwise to maximum setting initially. When the room is warm enough, reduce the setting slowly until the heater just clicks off.

The heater will now cycle on and off to maintain your selected room temperature. An audible click may be heard when the thermostat operates - this is normal.

Note : If the heater does not come on when the thermostat is at a low setting, this is normally because the room is warmer than the thermostat setting and is not a fault.

* When the heat control is set to  for cool blow, set the thermostat control to maximum.

Position  will turn the heater on and off to maintain a temperature of approximately 5°C.

Safety - overheat protection

For your safety, this appliance is fitted with a thermal cut-out. In the event that the product overheats, the cut-out switches the heater off automatically. To bring the heater back into operation, remove the cause of overheating, then turn off the electrical supply to the heater for a few minutes.

When the heater has cooled sufficiently reconnect and switch on the heater.

If the cut-out operates repeatedly, contact your supplier.

Cleaning

WARNING ALWAYS DISCONNECT FROM THE POWER SUPPLY BEFORE CLEANING THE HEATER.

Do not use detergents, abrasive cleaning powders or polish of any kind on the heater.

Wipe with a dry cloth to remove dust and a damp cloth (not wet) to clean off stains. Be careful not to allow moisture into the heater.

Ensure that dust or fluff does not accumulate inside the heater as this could lead to overheating of the element. Use a vacuum cleaner to remove any fluff which does accumulate.

Recycling



For electrical products sold within the European Community.

At the end of the electrical products useful life it should not be disposed of with household waste. Please recycle where facilities exist. Check with your Local Authority or retailer for recycling advice in your country.

Model Identifier(s):		DEUF2	
Heat output			
Nominal heat output	P _{nom}	2.0	kW
Minimum heat output (indicative)	P _{min}	0.8	kW
Maximum continuous heat output	P _{max,c}	2.0	kW
Auxiliary electricity Consumption			
At nominal heat output	e _{lmax}	0.0	kW
At minimum heat output	e _{lmin}	0.0	kW
In standby mode	e _{lSB}	0.0	kW
Type of heat output/ room temperature control			
Mechanical thermostat room temperature control			Yes
Contact details		GDHV Millbrook House, Grange Drive, Hedge End, Southampton. SO30 2DF	

Warranty

What does a Dimplex Warranty cover?

Dimplex products deliver reliable service for normal, household use in domestic settings. All Dimplex products are individually tested before leaving the factory.

If you are a consumer and you experience a problem with your Dimplex product, which is found to be defective due to faulty materials or workmanship within the Warranty Period, this Dimplex Warranty will cover repair or - at the discretion of Dimplex - replacement with a functionally equivalent Dimplex product.

The Dimplex Warranty Period is 1 calendar year from the date of purchase of your Dimplex product, or the date of delivery of the product, if later. The Dimplex Warranty is conditional upon you providing the original purchase receipt as proof of purchase. Please therefore retain your receipt as proof of purchase.

If you do experience a problem with your Dimplex product please call the Helpline on **+44 [0]344 879 3588** or visit <https://www.dimplex.co.uk/support>. For ROI please email serviceireland@glendimplex.com or call **+353(0)1 842 4833**. We will need details of your Dimplex product and a description of the fault which has occurred. Once we receive your information and proof of purchase we will contact you to make the necessary arrangements.

If your Dimplex product is not covered by this Dimplex Warranty there may be a charge to repair your product. However, we will contact you for agreement to any charges before any chargeable service is carried out.

What is not covered by a Dimplex Warranty?

The Dimplex Warranty does not cover any of the following:

Any fault or damage to your Dimplex product due to faulty materials or workmanship occurring outside the 1 year Warranty Period.

Any fault or damage occurring to any pre-owned Dimplex product or to any other equipment or property.

Accidental damage to your Dimplex product or damage to your Dimplex product from external sources (for example, transit, weather, electrical outages or power surges).

Fault or damage to your Dimplex product which is:

- Not due to faulty materials or workmanship or which is due to circumstances outside Dimplex's control.
- Caused by use of your Dimplex product for anything other than normal domestic household purposes in the country where it was purchased.
- Caused by any misuse, abuse or negligent use of the Dimplex product, including but not limited to any failure to use it in accordance with the Operating Instructions supplied with the product.
- Caused by any failure to assemble, install clean and maintain your Dimplex product in accordance with the Operating Instructions supplied with the product unless this was carried out by Dimplex or its authorised dealers.
- Caused by repairs or alterations to your Dimplex product not carried out by Dimplex service personnel or its authorised dealer(s).
- Caused by use of any consumables or spare parts for your Dimplex product which are not Dimplex -specified.

Terms and Conditions

The Dimplex Warranty is valid for Dimplex from the date of purchase of your Dimplex product from a recognised retailer in the country of purchase and use, or the date of delivery of the product if later, always provided the original receipt has been retained and is produced as proof of purchase.

You must provide to Dimplex or its authorised agents on request the original receipt as proof of purchase and - if required by Dimplex - proof of delivery. If you are unable to provide this documentation, you will be required to pay for any repair work required.

Any repair work under the Dimplex Warranty will be carried out by Dimplex or its authorised dealer(s) and any parts that are replaced will become the property of Dimplex. Any repairs performed under the Dimplex Warranty will not extend the Warranty Period.

Any replacement of your Dimplex product by Dimplex during the Warranty Period will start the 1 year Warranty Period afresh from the date of delivery of the replacement Dimplex product to you.

The Dimplex Warranty does not entitle you to recovery of any indirect or consequential loss or damage including but not limited to loss or damage to any other property.

The Dimplex Warranty is in addition to your statutory rights as a consumer and your statutory rights are not affected by this Dimplex Warranty.

Contact Dimplex

A brand of the GDC Group Limited, trading as Glen Dimplex Heating & Ventilation

If you have any questions about what the Dimplex Warranty covers and does not cover or how to claim under the Dimplex Warranty, please contact us:

GDHV, Grange Drive, Hedge End, Southampton SO30 2DF

Telephone: 0344 879 3588

Email: customer.services@glendimplex.com

Visit: www.dimplex.co.uk