

Contact Details

Please note that some of the contact details on this PDF document may not be current.

Please use the following details if you need to contact us:

Telephone: 0844 879 3588

Email: customer.services@gdcgroup.co.uk

The customer support section of our website also features a wide range of information which may be of use to you and is available 24 hours a day. It includes:

- Operating and installation instructions
- Easy 'How to use' guides for storage heaters
- Service and repairs
- Where to buy our products
- Literature downloads
- Heating requirement calculator

Visit - www.dimplex.co.uk/support

Dimplex

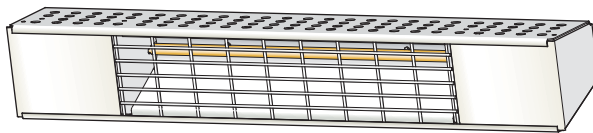

CPH10 & CPH15 Compact Outdoor Heaters

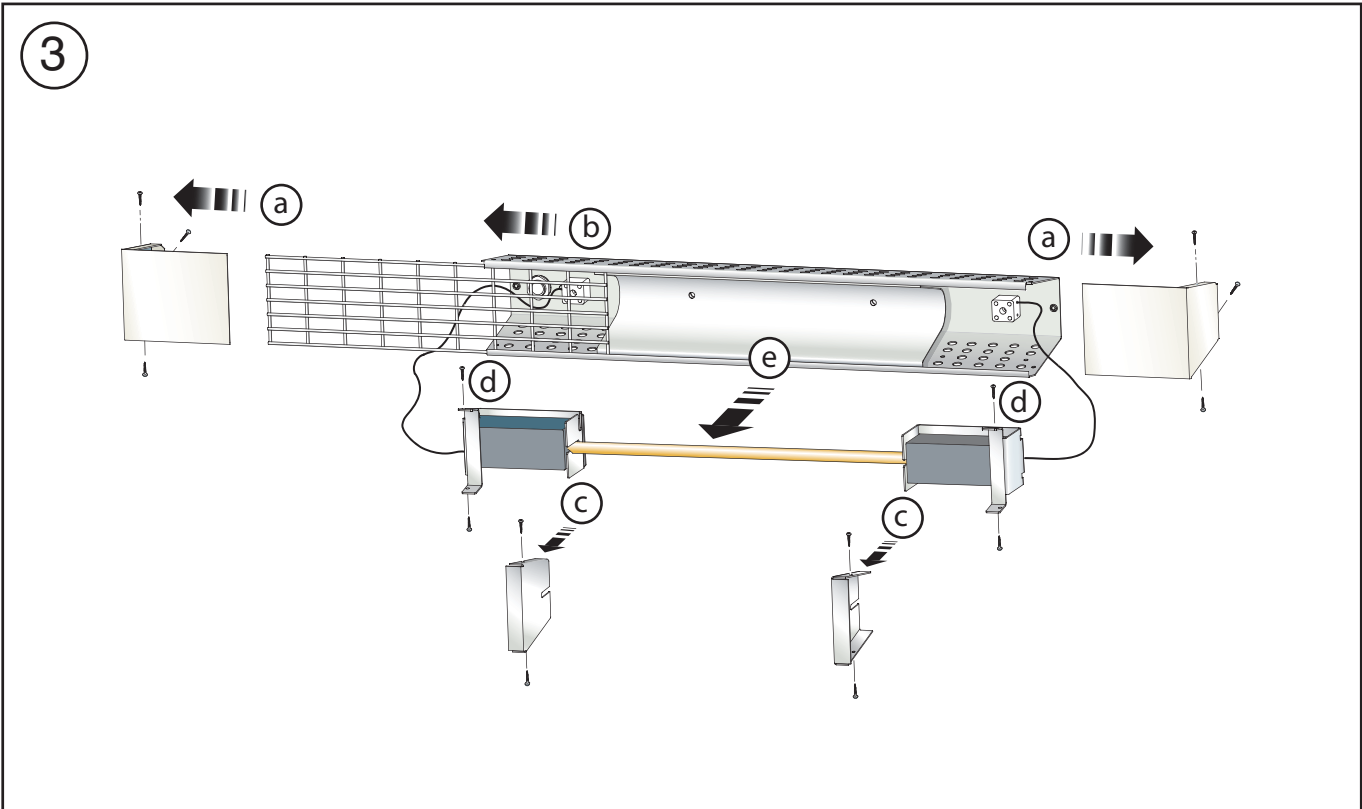
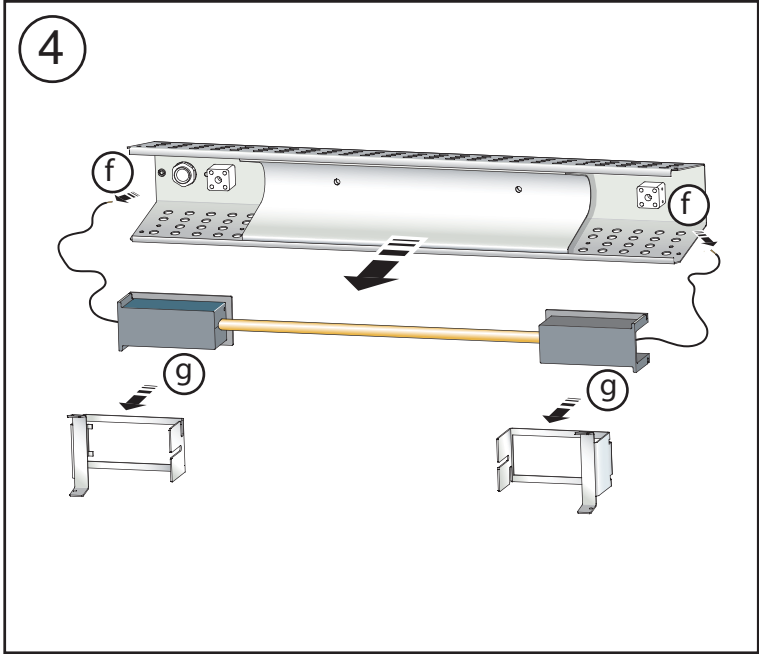
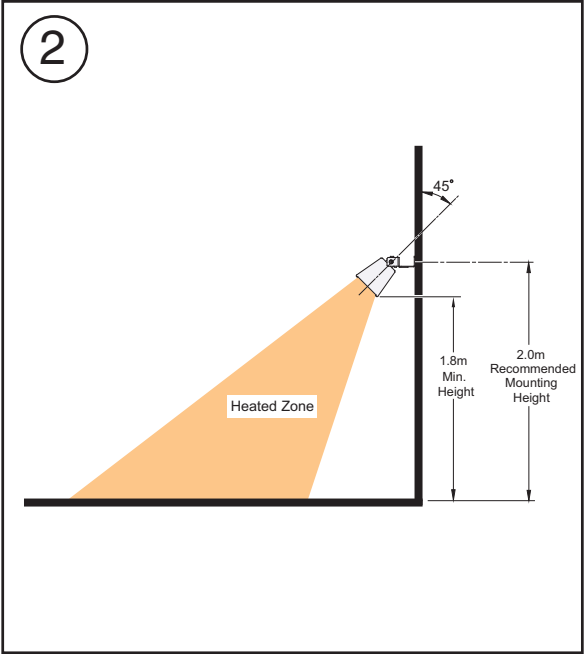
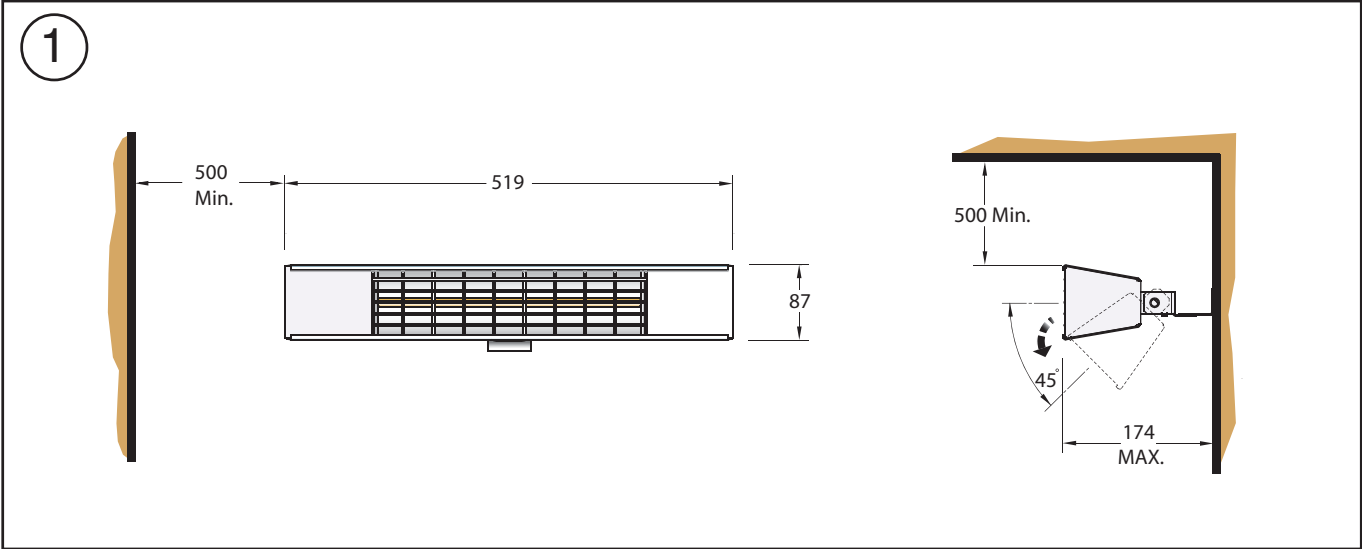

Dimplex Compact Outdoor Heaters

Model(s) : CPH10 & CPH15

(IPX5)

THESE INSTRUCTIONS SHOULD BE READ CAREFULLY AND RETAINED FOR FUTURE REFERENCE

Important Safety Advice

Because the heater contains no moving parts little maintenance is required. Before undertaking any maintenance work on the heater due attention must be paid to the following:

This heater is designed to be horizontally mounted on a wall. It must not be ceiling mounted or mounted vertically under any circumstances.

Always ensure a safe mounting height, at or above a minimum height of 1.8 metres from ground level, so that the heater can not be touched when in operation.

The heater must be wall mounted level $\pm 5^\circ$ to the horizontal.

Do not locate the heater immediately above or below a fixed socket outlet or connection box.

Always disconnect the heater from the electricity supply before attempting to work on or near it.

Always ensure a safe means of access using an access tower or properly supported ladder.

Do not cover the heater.

Keep combustible materials away from the heater.

Do not position patio furniture, sunshades, awnings and other combustible materials too close to the heater.

Do not look into the heater for prolonged periods

Do not use the heater if the elements are broken - as injury may occur.

Allow adequate time (minimum of 30 mins.) for the elements and body casing to cool before attempting to work on the heater.

Do not allow the supply cord to sit or hang in front of the heater while in use.

The supply cord should be regularly examined for signs of damage and the appliance is not to be used if the cord is damaged.

If the supply cord is damaged, it must be replaced by an assembly available from the manufacturer or service agent.

Note: Provide sufficient slack to the cable to allow for angular adjustment of the body.

The bulbs are extremely fragile and must be handled with extreme care at all times. Always handle the Halogen bulb without touching the glass (by gripping the ceramic ends gently but firmly) to maximise bulb life. If the bulb is accidentally touched by bare fingers remove the fingerprint with a soft cloth moistened with methylated spirits.

General

The CPH range of heaters are especially designed for use on patio areas. The heaters provide warmth and comfort for recreational areas. The CPH10 & CPH15 use halogen elements which produce a high proportion of their output in the short-wave infra-red spectrum. This provides a high comfort factor – similar to the natural energy from the sun.

The IPX5 rating means the appliance is suitably rated to be permanently installed either internally or externally.

Electrical

The installation of this appliance should be carried out by a competent electrician and be in accordance with the current IEE wiring regulations and any local or insurance regulations.

The CPH10 & CPH15 are designed for use on a 230-240V AC single phase supply. A double pole isolating switch with a minimum separation of 3mm in each pole must be fitted to facilitate isolation. This switch must either be positioned inside a building or have an IP rating against water ingress suitable for external installation. The appliance must be supplied through a residual current device (RCD) having a rated residual operating current not exceeding 30mA. The RCD should be type 3 or C rated, with a tripping coefficient of 7-10 times the rated current. Any other switching device should be Tungsten lamp rated. The appliance must be connected to a socket-outlet having an earthing contact (for Class I appliances).

Installation – Wall Mounting

Heaters are supplied with an integral mounting bracket which may be fixed through the mounting holes to any suitable structure. The bracket allows the heater to be inclined at the required angle. The recommended fixing height to the centre line of the bracket is 2.0m from ground level - see Fig. 2. The integral mounting bracket may be removed by fully unscrewing to facilitate its fixing. The siting of the heater(s) should be such as to allow an even and uninterrupted distribution of radiation to the area(s) to be heated. Heaters are most effective when the beam angle is inclined down at an angle of between 30° to 45° to the vertical - see Fig. 2. When deciding upon the best location, consideration must be given to the following requirements:

- Avoid structures which might vibrate e.g. crane gantries. These could adversely affect element life
- Comfort and safety could be compromised unless the heater is mounted at or above 1.8m from ground level.
- Allow a minimum of 500mm minimum clearance between the top of the heater and any surface - see Fig. 1.

Element Replacement (see Fig's 3 & 4)

WARNING – BEFORE UNDERTAKING THIS TASK ENSURE THE HEATER IS DISCONNECTED FROM THE ELECTRICITY SUPPLY AND LEFT TO COOL FOR A MINIMUM OF 30 MINUTES.

- Remove six screws to release both end caps - see Fig. 3.
- Slide the protective guard out on either side - see Fig. 3.
- Remove four screws to release both reflector ends - see Fig. 3.
- Remove four screws and remove both sealing brackets - see Fig. 3.
- Lift out the lamp assembly - see Fig. 3.
Note: Take care not to touch the bulb with bare hands.
- Disconnect both element wires from the terminal blocks - see Fig. 4.
- Remove the rubber ends from the lamp - see Fig. 4.

Replace the lamp and reverse the procedure to re-assemble the heater.

Cleaning and User Maintenance

WARNING: BEFORE UNDERTAKING CLEANING OR MAINTENANCE WORK ON THE APPLIANCE, DISCONNECT THE ELECTRICITY SUPPLY.

Since the appliance contains no moving parts little maintenance is required beyond cleaning and element replacement. It is however essential that the heater is not operated with an accumulation of dust or dirt on the element, as this can cause a build up of heat and eventual damage. For this reason the heater must be inspected regularly, depending upon conditions and at least at yearly intervals. Allow adequate time for the element and body casing to cool before attempting to work on the heater - a minimum time of 30 minutes is recommended.

If the bulb is accidentally touched by bare fingers remove the fingerprint with a soft cloth moistened with methylated spirits.

Recycling

For electrical products sold within the European Community.



At the end of the electrical products useful life it should not be disposed of with household waste.

Please recycle where facilities exist. Check with your Local Authority or retailer for recycling advice in your country.

After Sales Service

Your product is guaranteed for one year from the date of purchase.

Within this period, we undertake to repair or exchange this product free of charge (excluding element & subject to availability) provided it has been installed and operated in accordance with these instructions. Your rights under this guarantee are additional to your statutory rights, which in turn are not affected by this guarantee.

Should you require after sales information or assistance with this product please go to www.dimplex.co.uk where you will find our self help guide by clicking on "After Sales" or ring our helpdesk on 0845 600 5111 (UK) or 01 842 4833 (R.O.I.) .

Spare parts are also available on the website

www.dimplex.co.uk

Please retain your receipt as proof of purchase.

Dimplex UK Ltd.
Millbrook House
Grange Drive
Hedge End
Southampton
Hampshire. SO30 2DF

www.dimplex.co.uk

Republic of Ireland Tel. 01 8424833