

## **Contact Details**

Please note that some of the contact details on this PDF document may not be current.

Please use the following details if you need to contact us:

Telephone: 0844 879 3588

Email: [customer.services@gdcgroup.co.uk](mailto:customer.services@gdcgroup.co.uk)

The customer support section of our website also features a wide range of information which may be of use to you and is available 24 hours a day. It includes:

- Operating and installation instructions
- Easy 'How to use' guides for storage heaters
- Service and repairs
- Where to buy our products
- Literature downloads
- Heating requirement calculator

Visit - [www.dimplex.co.uk/support](http://www.dimplex.co.uk/support)

## INNER CARTON CONTENTS

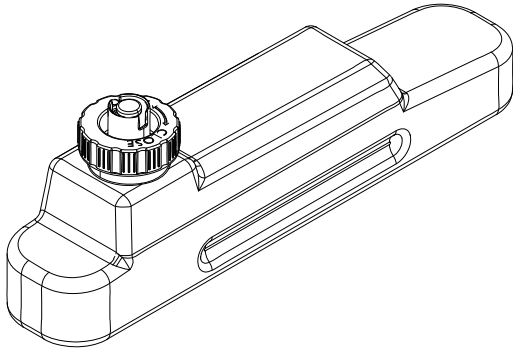

### Water Tank:

Ensure that the water tank is filled with filtered water. See 'Filling the water tank' in your instructions

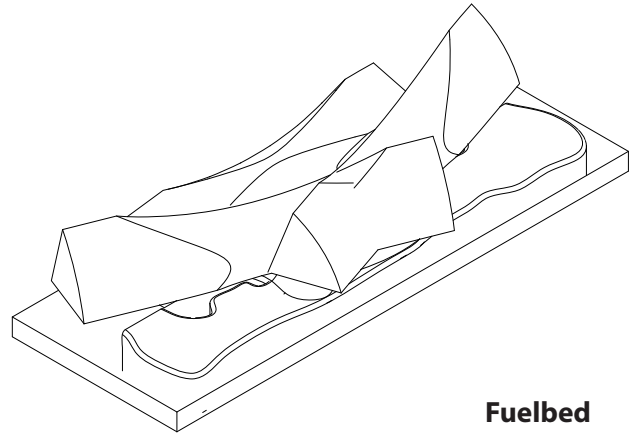

### Fuelbed

### Power Cable

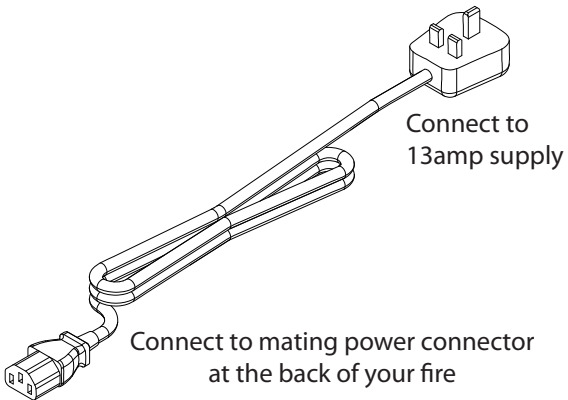

### Set of 4 Lamps

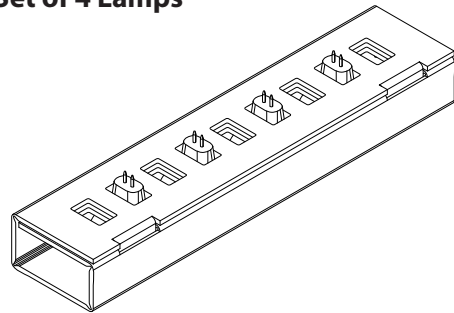

### Remote Control Handset + 2xAAA Batteries

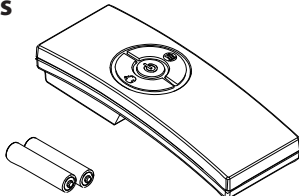

Refer to your instruction manual for operation

### Transducer Unit

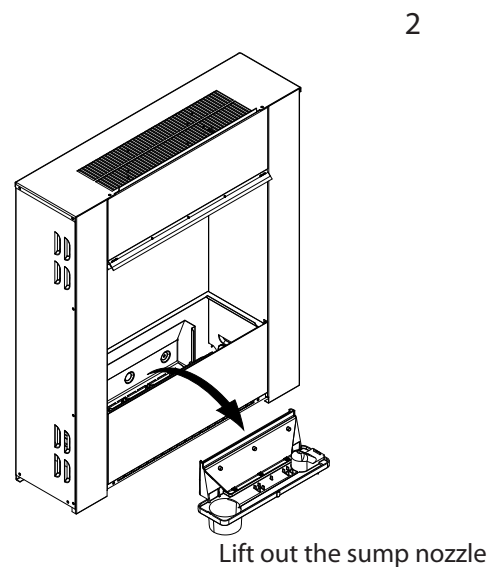
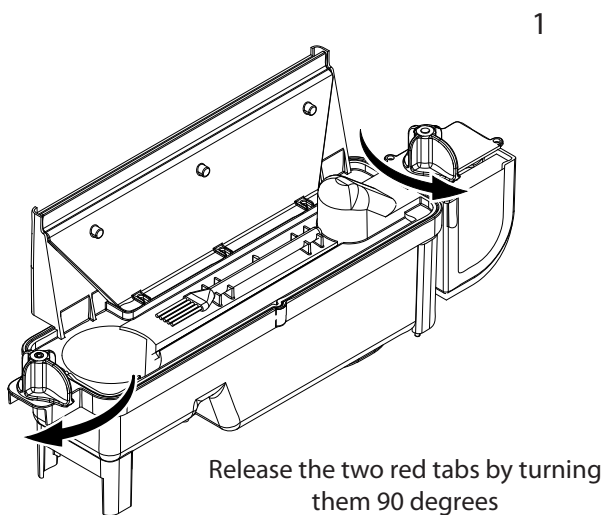
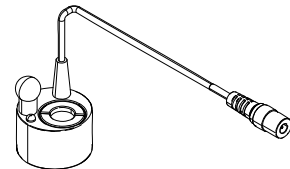

3

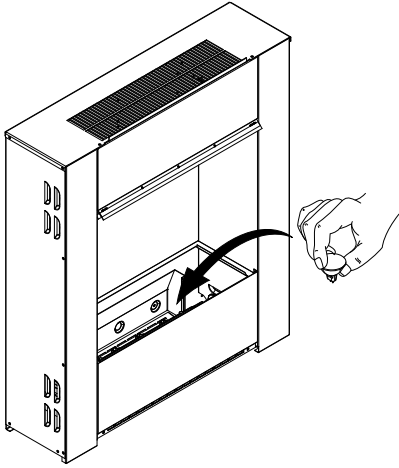

Insert lamps into lamp holders, carefully locating the pins into the holes

4

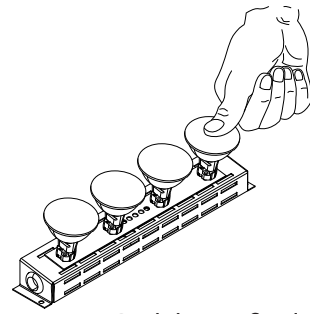

Push lamps firmly into place

6

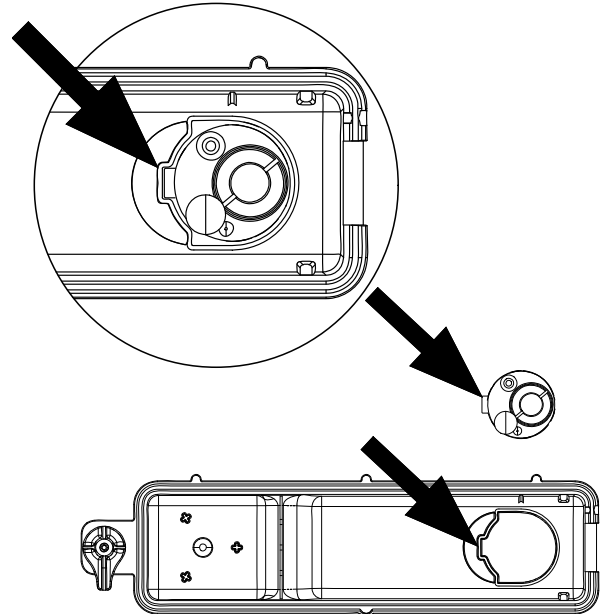

Locate the tab on the transducer unit into the moulded recess in the base of the sump

5

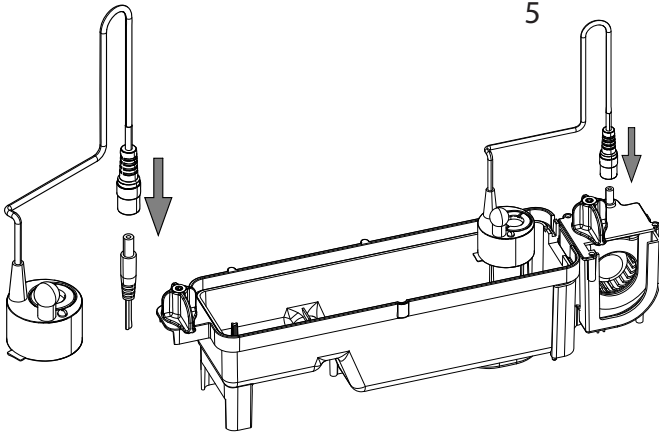

Place the transducer unit into the sump and make the connection

7a

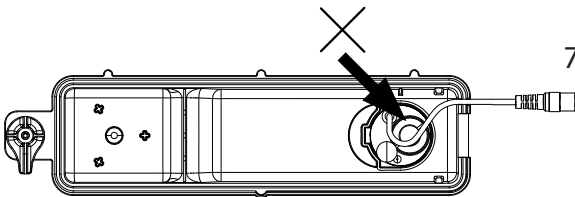

7b

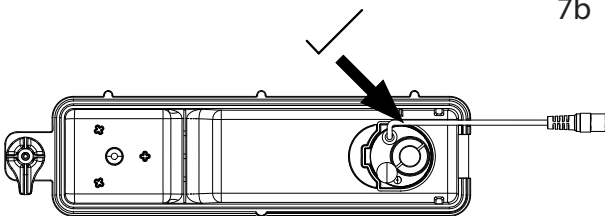

Ensure that the cable does not obstruct the Transducer Disc. To prevent the cable becoming pinched between the nozzle and the sump, place the cable in the slot in the wall of the sump.

8

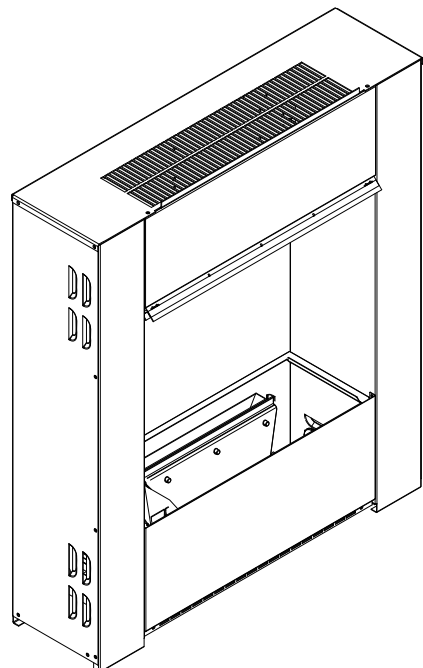

Replace nozzle by repeating steps 1 and 2 in reverse