

UNIDARE

WMS(N) AUTOMATIC WMX(N) MANUAL STORAGE HEATER RANGE

MODELS: WMX706N - 6kWh WMS/X712N - 12kWh
 WMS/X718N - 18kWh WMS/X724N - 24kWh

INSTALLATION AND OPERATING INSTRUCTIONS

IMPORTANT

PLEASE READ THIS LEAFLET CAREFULLY AND RETAIN FOR FURTHER USE
NOTE ALSO THE INFORMATION GIVEN ON THE HEATER

- ✦ The Installation must be carried out by trained personnel.
- ✦ A means for disconnection must be incorporated in the fixed wiring by a double pole switch with a contact separation of a minimum of 3mm and in accordance with the current IEE Wiring Regulations.
- ✦ The heater must not be installed immediately below a fixed socket outlet.
- ✦ The heater is not suitable for connection to a 30A ring circuit.
- ✦ Do not position the heater under windows where curtains can contact the heater casing.

- ✦ WARNING - THE SURFACES ON THIS HEATER CAN BE HOT.
- ✦ This heater meets EN60335 safety requirements. However, any heater type becomes hot in normal operation. Care must be taken to ensure that prolonged skin contact with the heater does not occur.
- ✦ WHERE YOUNG CHILDREN, INFIRM PERSONS, OR THE AGED ARE PRESENT THIS APPLIANCE MUST BE ADEQUATELY GUARDED. Contact your installer or the manufacturer for further advice.
- ✦ This appliance is very heavy and must be securely fixed to a wall. DO NOT UNDER ANY CIRCUMSTANCES ATTEMPT TO MOVE OR REPOSITION THIS HEATER WITHOUT SEEKING EXPERT ADVICE.
- ✦ To maintain stability, it is essential that the heater is placed on a level surface.
- ✦ This heater must be installed where it is impossible for switches and other controls to be touched by a person using a bath or shower.
- ✦ IMPORTANT - Due to the newness of materials the heater will produce a slight smell for the first few days of operation. ROOMS MUST BE WELL VENTILATED AND YOUNG CHILDREN, CAGED BIRDS, OR PERSONS WITH RESPIRATORY COMPLAINTS MUST NOT REMAIN IN CLOSE PROXIMITY TO THE HEATER DURING THE FIRST 48 HOURS OF THE COMMISSIONING PERIOD.
- ✦ IF, DURING ANY REASSEMBLY OF THE HEATER, A PART OF THE THERMAL INSULATION SHOWS DAMAGE OR DETERIORATION WHICH MAY IMPAIR SAFETY, IT SHOULD BE REPLACED BY AN IDENTICAL PART.

INSTALLATION INSTRUCTIONS

PREPARATION

The heater will arrive separately from its storage bricks, the following bricks will be required:

Model 706N - 4 bricks
 Model 712N - 8 bricks
 Model 718N - 12 bricks
 Model 724N - 16 bricks

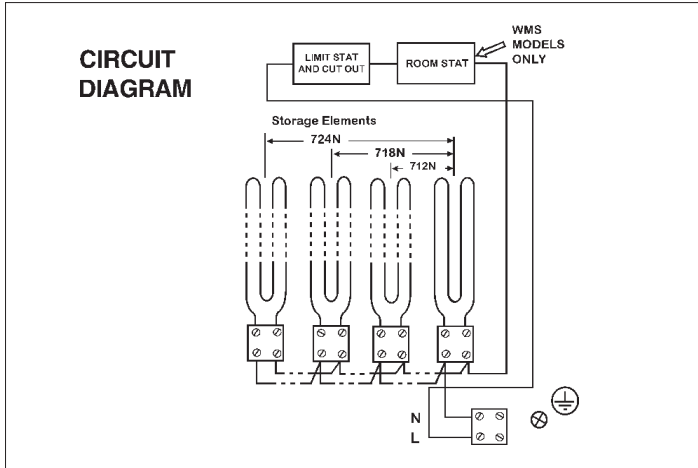

WARNING - This appliance must be earthed

Only heat resisting cable (min. rating T85) should be used. The wires in the mains cable will be coloured as follows:-

GREEN & YELLOW	-	EARTH
BLUE	-	NEUTRAL
BROWN	-	LIVE

SUGGESTED FIXINGS

SOLID BRICK/BLOCK: No. 10 Rawplug fibre inserts, 5.5mm drill bit. Drill hole 6mm deeper than rawplug length.

PLASTERBOARD - If possible locate studding and use No. 10 woodscrews directly into the wood, otherwise M5 rawplug intersets are suitable.

NOTE: FOR OTHER WALL TYPES (e.g. Timber frame and hollow concrete) **SEEK SPECIALIST ADVICE.**

FIXING ASSEMBLY

1. ENSURE THAT FIXING KIT AND FEET HAVE BEEN LOCATED BEFORE DISPOSING OF PACKAGING.
2. Fit the feet with the open end of the foot to the front of the heater. Secure each foot using two taptite screws provided in the fixing kit.

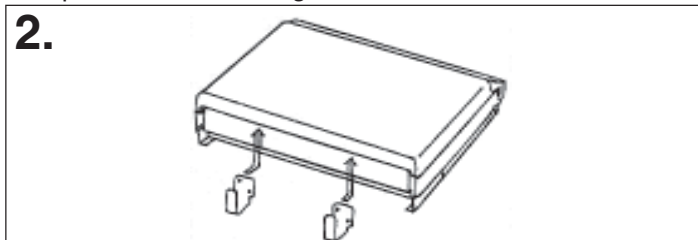

3. **WMS MODELS ONLY** - The Room Sensor is located at the rear of the right hand side of the heater. Carefully slide the sensor plate down from its transit position to its operational position.

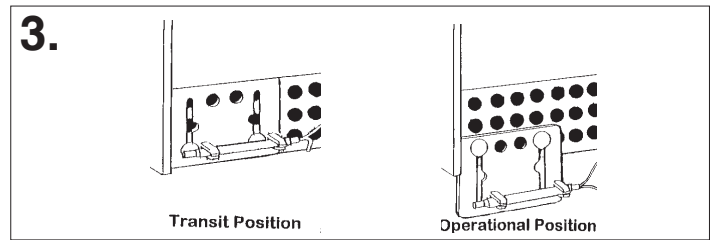

4. Place the heater on its feet and in the desired position against the wall. Ensure the heater is based on a firm level surface at least 75mm from any end wall and at least 250mm below any shelf or similar projection. Cut away any gripper rod or carpet which would prevent the heater sitting firmly on the floor.

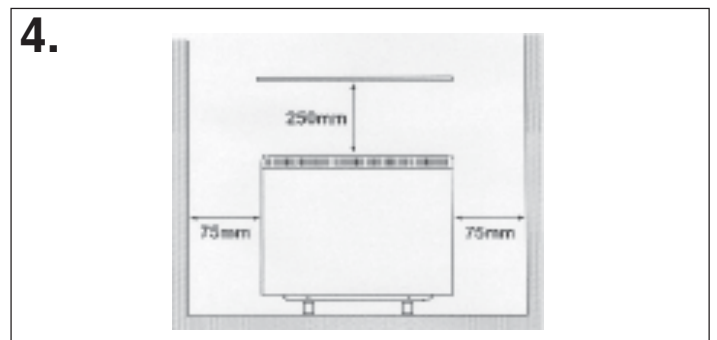

5. Mark the position of the two outside corners of the wall bracket with the heater pushed tight against the wall. Remove the wall bracket from the heater by removing the screw at each end. Place the heater to one side and reposition the bracket against the wall using the corner marks for alignment.

Four fixing positions must be chosen for the 724N, three for the 718N and two for the 712N and 706N. Mark the positions for the fixing holes - two at the extreme ends and the others spaced evenly between them. Remove the bracket from the wall, drill the holes in the positions marked, and insert suitable fixings previously described. Secure the wall bracket to the wall.

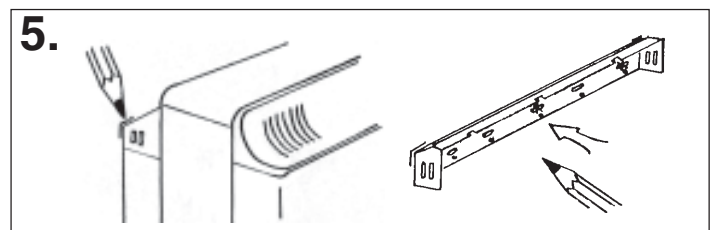

6. If mains connection is to be made from the left side, at this point the mains lead must be secured to the back of the heater using ties provided in the fixing kit.

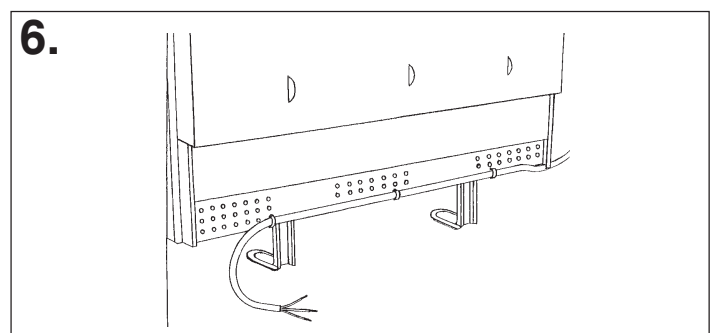

7. THE FOLLOWING MUST BE APPLIED WHEN FIXING THE HEATER TO THE WALL BRACKET

- i) If no skirting board is present secure the heater through the wall bracket slots closest to the wall.
- ii) If 100mm (4in.) skirting is present secure the heater through the outer slots.
- iii) If skirting taller than 150mm (6in.) is present this must be reduced to 150mm (6in.) over the entire width of the heater plus 25mm (1in.) at each end.

Do not fully tighten these screws until the bricks are loaded into the heater as some settling of the heater may occur.

NOTE: NEVER REMOVE THESE SCREWS WITHOUT FIRST UNLOADING THE HEATER.

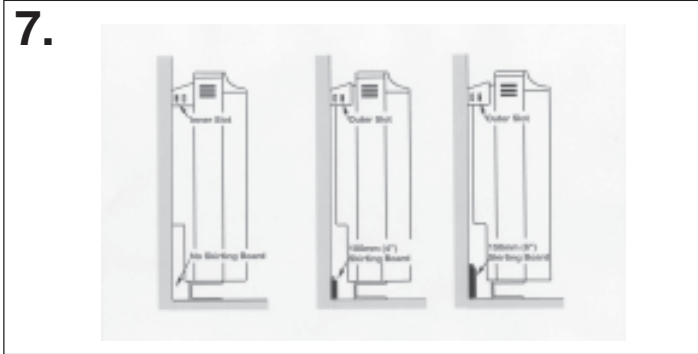

8. Remove the front panel by removing the two self tapping screws along its bottom edge. With hands positioned on each side of the panel, lift upwards to unhook the top edge whilst pressing down on the top panel with your thumbs. The panel can now be lifted clear and set to one side.

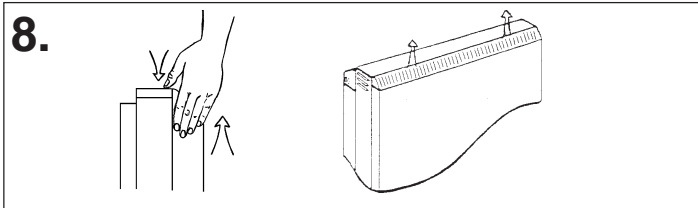

9. Remove the inner front by removing the screws along its top and sides. As the front insulation is attached care must be taken when lifting this panel from the heater and placing it to one side. Remove the internal packing by sliding it up and off the elements taking care not to damage the insulation.

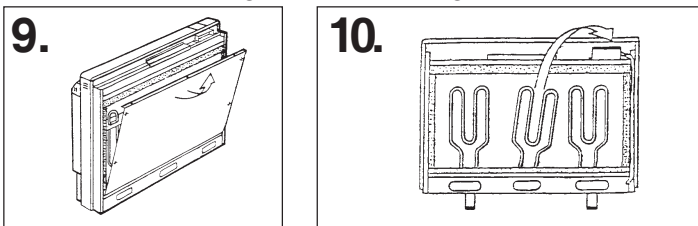

10. Remove one element to allow access for the back rows of bricks. On the 724N remove the element to the right of centre, on the 718N remove the central element, on the 712N the left hand element should be removed and, on the 706N, there is only one element.

Loosen the two screws securing the element tails in the ceramic connector block, and lift the element up and out of the heater.

11. Carefully fit the bottom row of the back layer of bricks placing the two end bricks in position first with the recess towards the element. Fit the top row of bricks also with the recess towards the element.

12. Refit the element which has been removed by feeding the tails down through the hole in the base insulation and into the connector block. Ensure the element is fully pushed home then securely tighten the two screws in the block.

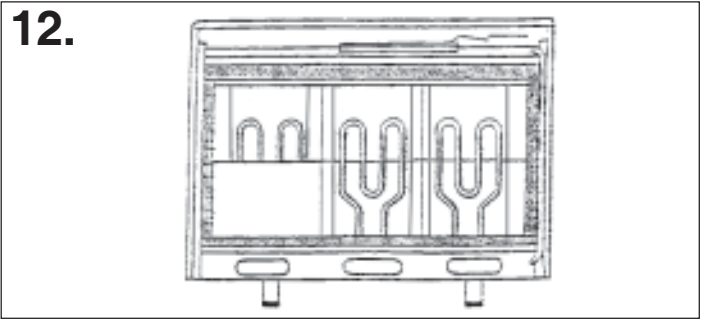

13. Fit the front layer of bricks again with the recess towards the element. The complete core will comprise:

706N - 1 x 4 Brick Columns
712N - 2 x 4 Brick Columns
718N - 3 x 4 Brick Columns
724N - 4 x 4 Brick Columns

14. Replace the inner front complete with insulation by locating its bottom edge behind the front lip of the chassis and inserting retaining screws along the top and both sides.

15. For models 712N, 718N and 724N only, check that the flap mechanism operates freely on its hinges and that with the output control set to 1 the flap is correctly seated in its closed position.

16. Feed the mains cable through the cable clamp and make connections as marked on heater. Pull back any slack through the clamp and tighten clamping screw.

WARNING - This appliance must be earthed

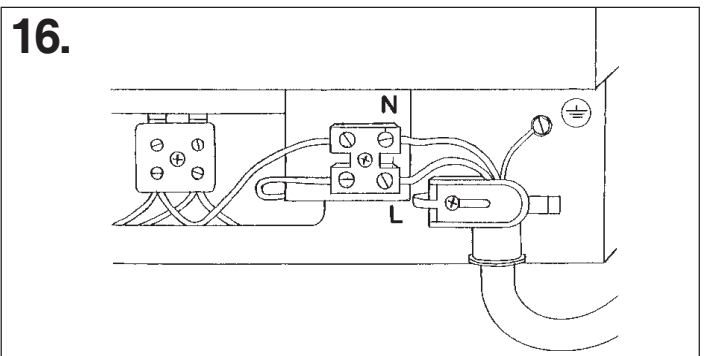

17. Replace outer front panel and grille by hooking the grille into its retaining slot on the top panel and lowering it into position. Secure the front panel with the two self tapping screws.

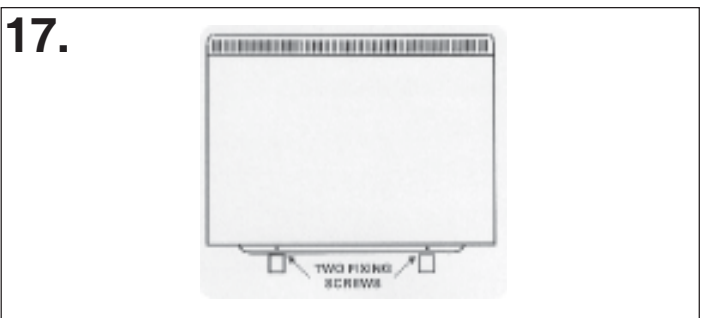

18. Check that the screws securing the heater to the wall bracket have been fully tightened.

IT IS ESSENTIAL THAT ALL SCREWS ARE REPLACED TO ENSURE EARTH CONTINUITY.

Once installed do not attempt to reposition the heater without first obtaining the services of a competent electrician.

OPERATING INSTRUCTIONS

OPERATION

This storage heater takes in Energy when electricity tariffs are low and dissipates it when tariffs are normal.

SAFETY INSTRUCTIONS

1. Ventilate rooms well during commissioning
2. Do not move the heater in any way once installed without the services of a competent electrician.
3. Do not cover the heater with clothing etc. at any time or position furniture close to or against the heater.
4. Ensure a clearance of at least 150mm between heaters and curtains.
5. Floor standing heaters must only be fitted with the back against a wall.
6. Should your heater fail to operate either employ the services of a competent electrician or Telephone (0870) 7270 101

ALSO REFER TO COVER PAGE

COMMISSIONING

Set both the Input Control and the Output Control to 6 and leave the heater for 48 hours.

Following the commissioning period adjust the controls as stated below.

SETTING THE CONTROLS

The controls are located under the hinged flap at the top right hand corner of the heater.

To adjust the controls on the heater use a coin and engage it in the slots provided on the top surface of the knob. There are no user adjustable controls on the WMX706N.

CONTROL FUNCTIONS

THE INPUT CONTROL

For models WMS712N, 718N, 724N only:

This heater is fitted with a user adjustable automatic input control which varies the charge taken in response to weather conditions taking into account the amount of energy already stored in the heater.

Set at 6 the heater takes maximum charge and at 1 the heater takes a minimum charge at any room temperature. The casing of the heater, particularly in late evening, may feel cool, this is quite normal. The input control may require a few days experimentation before your comfort level is established.

Initially set the control to 4, the following evening if the room is too warm reduce to 3 or if it is too cool increase to 5. On subsequent evenings adjust by half divisions until our comfort level is achieved.

Having established the setting the input will automatically carry the amount of heat stored to compensate for weather variations.

For models WMX712N, 718N, 724N only:

Initially set the input to 4. If the heater does not maintain a satisfactory room temperature the following day this setting should be increased. Conversely if the room temperature is too high this setting should be reduced.

The input control should only require seasonal adjustments.

THE OUTPUT CONTROL

For all models except WMX706N

Most of the stored heat is radiated from the casing during the discharge period. However, some of the heat is emitted through the grille at the top of the heater and this additional heat (or boost) is regulated by the Output Control.

With this set to 6 the boost begins in the early afternoon. Turning the control towards 1 will progressively delay the commencement of the boost. At 3 the boost will start in the evening. Once set, the boost will repeat itself automatically day after day.

If no boost is required e.g. when the room will be unoccupied for a long period, set the Output Control to 1. With the control in this position, the heater will take less energy during the next charging up period.

CLEANING

To maintain the appearance of the heater wipe occasionally with a dry cloth when the heater is cool.

Do not use abrasive powders or furniture polish.

Discolouration of wall finishes can sometimes occur immediately above a storage heater due to the properties of some paints and decorating materials or the presence of environmental impurities in the air (such as soot or incense generated from the burning of candles etc.).

AFTER SALES SERVICE

Your Storage Heater is guaranteed for one year from date of purchase. We undertake to exchange or repair within the period, any part found to be defective due to a manufacturing fault. This guarantee does not affect your statutory rights. Should you require after sales service, please contact the supplier through whom you purchased the heater, or telephone (0870) 7270 101.

Please do not initially return faulty appliance, or part of an appliance, to us as this may result in transit damage and/or a delay in providing service.

Let us know your difficulty quoting the model number and serial number (located along the wall bracket). We will then take the appropriate action.



UNIDARE

Customer Services

Tel: (0870) 7270 101 Fax: (0870) 7270 102

Product Sales

Tel: (0870) 7270 103 Fax: (0870) 7270 104

Head Office

Tel: (0870) 0777117 Fax: (0870) 7270 109