

Smarter DM Electric Panel Heater SDM



Product Description

Smarter DM takes the standard PLXE panel heater and adds an RF module with Smarter DM firmware. This allows the panels to be controlled remotely through hotel booking systems etc.

Key Features

- Built-In RF Module.
- Smarter DM Firmware.
- Hardwired supply.
- Modern panel design with louvered forward facing grille for optimum heat circulation.
- Customisable heating with four time and temperature settings per day.
- Adaptive start pre-heating and open window detection auto-shutdown.
- Slimline design that covers traditional panel heater fixing marks.

Technical Details

Controls	Digitally controlled, Electronic Thermostat accurate to ($\pm 0.2^{\circ}\text{C}$). Setpoint range (7-30°C) Timer modes: 7 Day Programmable User Timer, Out All Day, Home All Day Continuous heat modes: Eco, Manual, Frost Protect. Additional modes: Away, Boost, Setback, Runback
Controller UI	<ul style="list-style-type: none"> • Graphical display with RGB backlight • Capacitive buttons with audio feedback • User replaceable battery (Coin-Type)
Controller Functions	<ul style="list-style-type: none"> • Open window detection • Adaptive-start, • Advance time period • Child Lock & Heater Lock (PIN-based)
Construction	<ul style="list-style-type: none"> • Durable epoxy-polyester powder coated steel casing with louvered forward facing grille • Advanced controls with cap-sense technology for total flexibility of heating
Element	Compact, finned, mineral filled sheathed element
Installation	<ul style="list-style-type: none"> • 1 H-frame wall bracket for easy fixing
Safety	<ul style="list-style-type: none"> • Thermal cut-out. Auto reset type • Overheat detection
IP Rating	IP24
Battery Backup	1 x CR2032 Lithium Manganese Dioxide 3V coin cell battery to backup real time clock (weight 3g). Battery life > 5 years.
Supply	1.3 metres fitted, 3 core for fused spur installation, 1/N/PE ~230-240 V, 50Hz Class I, with earth wire
Colour / Finish	Metal Chassis, Air Outlet Grille & Control Moulding - Traffic White (RAL 9016)

Dimensions

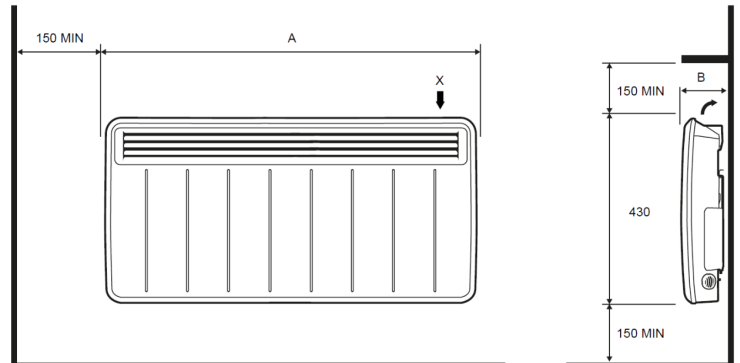

Model/Item No.(EAN-Code 5011139+Item No.)	PLX125E SDM
Output (kW)	1.25
Height (mm)	430
Width A (mm)	690
Depth B (mm)	108
Weight (Kg)	6.1
Packaging Details	
Height (mm)	470
Width (mm)	720
Depth (mm)	135
Packed Weight (Kg)	6.7
Ti	10
Hi	4
Pallet Quantity (2.4m high)	40

Warranty & Approvals

Approvals	UKCA, CE, BEAB
Warranty	2 Years
Country of Origin	United Kingdom
Manufacturer	Smarter DM, GDHV

Smarter DM Electric Panel Heater TL



Product Description

Smarter DM takes the standard PLXE panel heater and adds an RF module with Smarter DM firmware. This allows the panels to be controlled remotely through hotel booking systems etc.

Key Features

- Built-In RF Module.
- Smarter DM Firmware.
- Plugged supply.
- Modern panel design with louvered forward facing grille for optimum heat circulation.
- Customisable heating with four time and temperature settings per day.
- Adaptive start pre-heating and open window detection auto-shutdown.
- Slimline design that covers traditional panel heater fixing marks.

Technical Details

Controls	Digitally controlled, Electronic Thermostat accurate to ($\pm 0.2^{\circ}\text{C}$). Setpoint range (7-30°C) Timer modes: 7 Day Programmable User Timer, Out All Day, Home All Day Continuous heat modes: Eco, Manual, Frost Protect. Additional modes: Away, Boost, Setback, Runback
Controller UI	<ul style="list-style-type: none"> • Graphical display with RGB backlight • Capacitive buttons with audio feedback • User replaceable battery (Coin-Type)
Controller Functions	<ul style="list-style-type: none"> • Open window detection • Adaptive-start, • Advance time period • Child Lock & Heater Lock (PIN-based)
Construction	<ul style="list-style-type: none"> • Durable epoxy-polyester powder coated steel casing with louvered forward facing grille • Advanced controls with cap-sense technology for total flexibility of heating
Element	Compact, finned, mineral filled sheathed element
Installation	<ul style="list-style-type: none"> • 1 H-frame wall bracket for easy fixing
Safety	<ul style="list-style-type: none"> • Thermal cut-out. Auto reset type • Overheat detection
IP Rating	IP24
Battery Backup	1 x CR2032 Lithium Manganese Dioxide 3V coin cell battery to backup real time clock (weight 3g). Battery life > 5 years.
Supply	UK 3-pin plug with 10A fuse fitted
Colour / Finish	Metal Chassis, Air Outlet Grille & Control Moulding - Traffic White (RAL 9016)

Dimensions

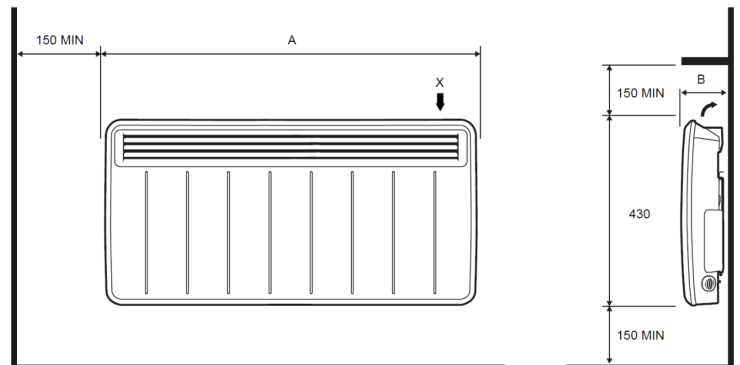

Model/Item No.(EAN-Code 5011139+Item No.)	PLX125E TL
Output (kW)	1.25
Height (mm)	430
Width A (mm)	690
Depth B (mm)	108
Weight (Kg)	6.1
Packaging Details	
Height (mm)	470
Width (mm)	720
Depth (mm)	135
Packed Weight (Kg)	6.7
Ti	10
Hi	4
Pallet Quantity (2.4m high)	40

Warranty & Approvals

Approvals	UKCA, CE, BEAB
Warranty	2 Years
Country of Origin	United Kingdom
Manufacturer	Smarter DM, GDHV